

PREDATOR® 1200 Portable Air Scrubber
Model PRED1200
INSTRUCTION MANUAL

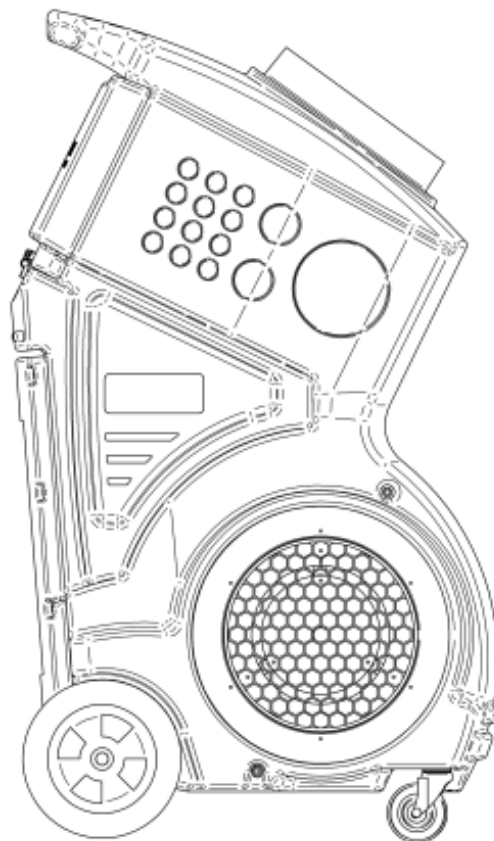

Patented - U.S. Design Patent No. D572,356

Abatement Technologies, Inc./Remediation Products Division

Abatement Technologies, Inc.
Georgia, USA
800-634-9091

Abatement Technologies Ltd.
Ontario, Canada
905-871-4720

www.abatement.com

Predator Portable Air Scrubber Model: Pred1200

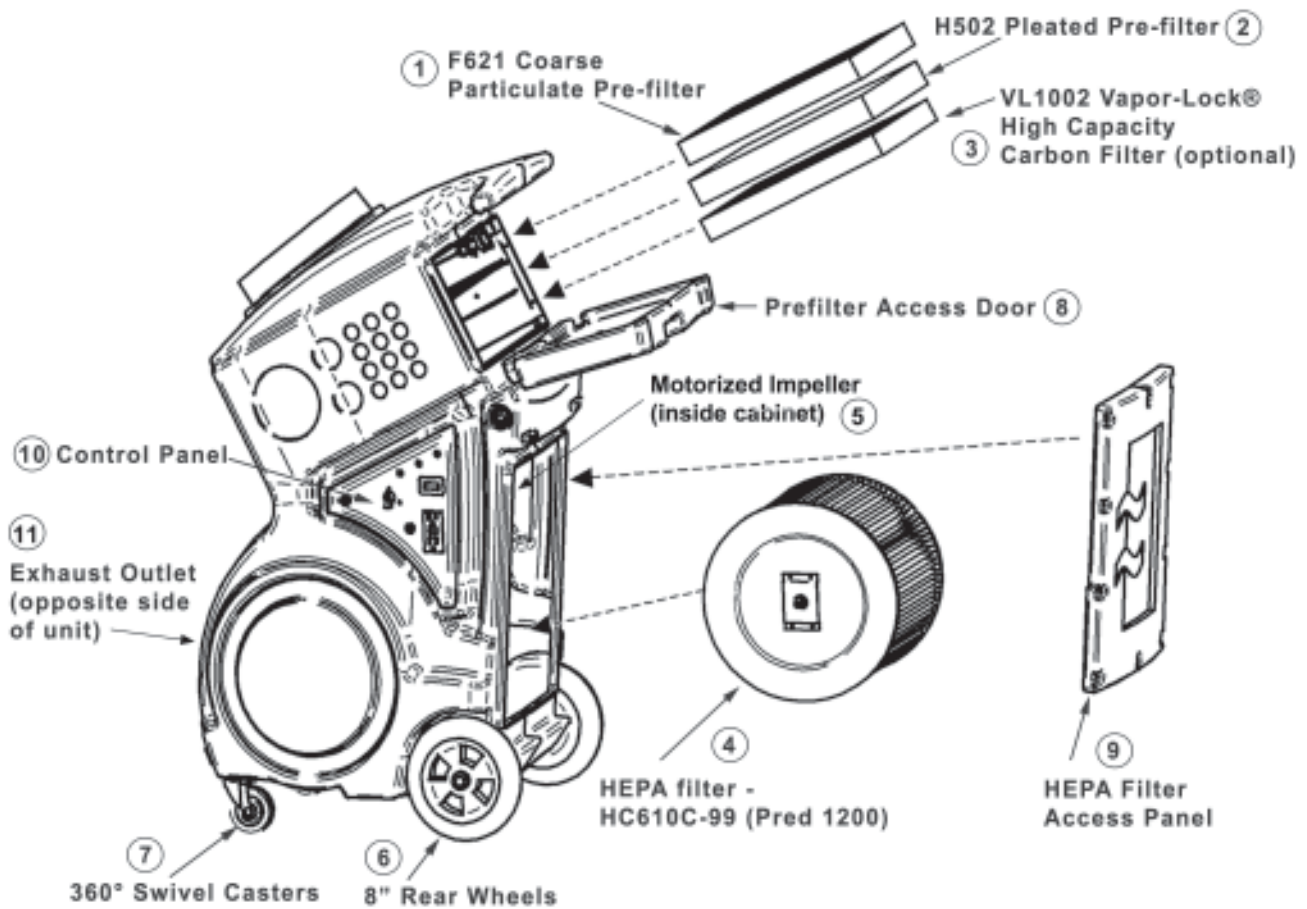

- | | |
|--|-----------------------------|
| 1. First Stage 1" Coarse/Particulate Pre-filter (P/N F621) | 6. 8" Rear Wheels |
| 2. Second Stage 2" Pleated Pre-filter (P/N H502) | 7. 360° Swivel Casters |
| 3. Optional Third Stage 2" High Capacity Vapor-Lock® Carbon Filter (P/N VL1002). | 8. Pre-filter Access Door |
| 4. Final Stage 99.97% HEPA Filter (P/N H610C-99) | 9. HEPA Filter Access Panel |
| 5. Motorized Impeller | 10. Control Panel |
| | 11. Exhaust Outlet |

PREDATOR Portable Air Scrubber
Model: PRED1200
Instruction Manual

© Abatement Technologies 2006 All Rights Reserved. No reproduction of any portion of this work is permitted without the express written permission of Abatement Technologies, Inc.

READ AND SAVE THESE INSTRUCTIONS!

- Note:**
- 1. Read and understand all operating instructions before using the PRED1200 Portable Air Scrubber.**
 - 2. Save this manual for future reference.**

This instruction manual provides important information on the use of the Predator Portable Air Scrubber (PAS) - model PRED1200. These instructions must be carefully followed in order to operate the unit safely and correctly. If there are any questions regarding the use of the unit, please contact Abatement Technologies immediately at 800-634-9091 U.S. or 905-871-4720 Canada.

Abatement Technologies strongly urges users of air filtration units and related accessories to follow the most recent guidelines and/or standards published by the Occupational Safety and Health Administration, Environmental Protection Agency, and all other federal, state, provincial and local regulations.

GENERAL INFORMATION

The PRED1200 is a multi-use air filtration device, equipped with pre-filters and a HEPA filter that are capable of filtering many airborne contaminants. An optional carbon pre-filter for capturing low concentrations of odors, vapors, gases, and volatile organic compounds, collectively known as OVG, is also available.

Types of contaminants captured by particulate pre-filters, HEPA filter, or carbon filters:

- | | | |
|----------------|---------------------------|--|
| • Dirt | • Lung-damaging particles | • Low concentrations of OVG |
| • Dust | • Metal fumes | • Low concentrations of Volatile Organic Compounds (VOC) |
| • Drywall dust | • Smoke | • Unpleasant nuisance odors |
| • Saw dust | • Mold and fungal spores | |

Note: To capture low concentrations of OVG, a Vapor-Lock® carbon filter must be used.

The PRED1200 is capable of providing particulate and odor, vapor, gas filtration with final stage filtration through a High Efficiency Particulate Air (HEPA) filter. The PRED1200 incorporates a series of particulate filters which successively remove larger size to smaller size particles from the air. In addition to providing HEPA filtration, the PRED1200 is primarily used in a negative pressure or recirculation mode. A negative pressure condition is created in order to confine contaminated airborne particles. This condition exists when the static pressure inside the room containing the unit is lower relative to the pressure of the environment outside the room. The static pressure differential is created and maintained by continuously exhausting air out of a given room at a faster rate than air enters the room from all other sources. In the recirculation mode, all of the filtered air is exhausted back into the room containing the unit.

Standard Air Cleaning Stages (filters supplied with the unit)

The PRED1200 comes equipped with two progressively efficient particulate pre-filters mounted in the pre-filter compartment, and a final stage HEPA filter, located in the lower section of the cabinet:

- The first-stage 1"-deep, coarse particulate pre-filter (F621) is designed to capture particles 100 microns or larger.
- The second-stage 2"-deep, pleated pre-filter (H502) is designed to capture particles 10 microns or larger.
- Each HEPA filter (H610C-99) is tested & certified to capture at least 99.97% (9,997 out of 10,000) 0.3-micron particles.

Note: The particulate filters in the PRED1200 do **not** remove odors, vapors or gases, including volatile organic compounds.

Optional Vapor-Lock Carbon Filters (must be purchased separately)

CAUTION: For General Ventilating Use Only. Do Not Use To Exhaust Hazardous Or Explosive Materials And Vapors. Refer to the REQUIREMENTS FOR SAFE OPERATION section of this manual.

Vapor-Lock® pleated, high-capacity, carbon filters (part # VL1002) are available for capturing OVG. This 2"-deep filter can be used in place of the second-stage H502 pre-filter, to reduce airborne OVG by chemically bonding the OVG molecules to the surface area of the carbon granules, via a process known as adsorption. The VL1002 filter also provides a similar level of particulate filtration efficiency to the H502 pre-filter.

Effective carbon adsorption is dependent upon the amount of carbon & exposed carbon granule surfaces, and the dwell (contact) time the OVG molecules have with the carbon granules. Operating the unit at lower speed settings to increase dwell time can therefore improve OVG adsorption, though it is highly unlikely that all of the OVG will be removed in one pass of air through the unit. Operating the unit in the recirculation mode can increase effectiveness, by exposing OVG particles to multiple passes through the Vapor-Lock filter.

It is almost impossible to provide accurate estimates to two commonly asked questions: “how much time will it take to capture all of the OVG?”, and “how do I know when a carbon filter should be replaced?” Unfortunately, unknown factors, such as concentration levels, fresh-air intake volume, temperature, and humidity prevent establishment of any more accurate ‘rule of thumb’ than one’s sense of smell. Since off-gassing of adsorbed OVG can occur when the adsorption capacity of the filter is reached, replace the carbon filter as soon as odor breakthrough is sensed. More detailed information on carbon adsorption can be found in an article titled: “**Activated Carbon: How Is It Used? How Does It Work?**” which can be found on the Links and Articles page of the Mold Abatement, Restoration & Renovation products section of the Abatement Technologies website, www.abatement.com.

TO DETERMINE THE REQUIRED NUMBER OF UNITS

Note: The Mold Abatement, Restoration & Renovation section of the Abatement Technologies website, www.abatement.com, includes a handy Air Change Calculator for all Predator models. This calculator provides users with a simple way to determine how many units are needed to provide a given number of air changes per hour (ACH) in any size containment area, and eliminates the need for user calculations. Simply enter the dimensions of the containment area, the ACH required, and select a built-in safety factor (SF) to compensate for potential losses due to filter loading, inlet and exhaust collars, ducting, etc. (Please note that use of a SF is recommended but not required). The calculator does the rest.

To determine the number of units required without using the Air Change Calculator, proceed as follows:

1. Calculate the volume inside containment (V), in cubic feet, by multiplying the length of the area (L) x the width of the area (W) x the ceiling height (H), in feet.
2. Determine the minimum ACH required in the job specification.
3. Select a safety factor (SF). Most users build-in between 10% (SF = 1.1) and 25% (SF = 1.25), or more. If you don’t wish to use a SF, proceed to Step 4.
4. Calculate the minimum total airflow required (Total CFM), as follows:
Total CFM = (V x ACH x SF) ÷ 60.
5. # Units Required = Total CFM ÷ CFM rating for the Unit.

6. Always round up to the next whole number. For example, if the minimum requirement is 2.1 units, 3 units are recommended, not 2.

Example 1:

How many 900 CFM units are needed to provide at least 6 ACH in a 25' x 30' x 10' containment area, with a 20% safety factor?

$$V = 25 \times 30 \times 10 = 7,500 \text{ Cubic Feet}$$

$$\text{Total CFM} = (7,500 \times 6 \times 1.2) \div 60 = 900 \text{ CFM}$$

$$\text{Minimum \# Units Req'd} = 900 \text{ CFM} \div 900 \text{ CFM (airflow of unit)} = \underline{\mathbf{1 \text{ Unit Required}}}$$

Example 2:

How many 900 CFM units are needed to provide at least 5 ACH in a 50' x 42' x 10' containment area, with a 25% safety factor?

$$V = 50 \times 42 \times 10 = 21,000 \text{ Cubic Feet}$$

$$\text{Total CFM} = (21,000 \times 5 \times 1.25) \div 60 = 2,188 \text{ CFM}$$

$$\text{Minimum \# Units} = 2,188 \div 900 = 2.43 = \underline{\mathbf{3 \text{ Units Required}}}$$

Note: This example illustrates the importance of a Safety Factor. If no SF were used, only 1,750 CFM (2 units) would be required.

PRED1200 TRANSPORT

Note: The PRED1200 can be transported in the horizontal position. If extremely poor road conditions exist, or excessive shock and vibration are expected, take precautionary measures by padding the unit to provide impact absorption during transport.

Caution: Always use caution when moving the PRED1200 inside a building or home. The unit weighs 70 pounds. Older structures with weakened floors or staircases may require special considerations for safe transport.

ELECTRICAL REQUIREMENTS

1. The PRED1200 requires a minimum of 110 volts AC, 60 Hz to operate properly; however, maximum airflow performance requires 120 volts AC, 60 Hz.
2. Due to momentary start-up current surge, the unit requires a 15 amp circuit that is free of other loads.
3. Extension cords used for the PRED1200 must be UL-listed, heavy duty No. 14/3 AWG industrial grade 3-wire type. Use of larger numerical gauge (lower capacity wire) power cord(s) may result in electrical shock, fire hazards and/or damage to unit. The cord(s) must be in good condition and in continuous lengths (no splicing) and should not exceed a total of 50 feet in length. Make certain that any extension cords used do not reduce power to the unit to less than 110 volts. Use of a voltmeter to confirm adequate voltage is recommended.
4. Check to ensure that any circuit to which the unit is connected is protected by a 15 ampere circuit breaker. The unit itself is equipped with a 12 amp circuit breaker.
5. The PRED1200 should be connected to a three-prong, properly grounded electrical outlet equipped with a Ground Fault Circuit Interrupt (GFCI) device. A GFCI is an electrical safety device that will trip the circuit and stop the flow of electricity if leakage of current is detected.
Important Note: The GFCI on the PRED1200 control panel only detects leakage of current from the unit or an electrical device plugged into the GFCI. The PRED1200 should be plugged into a GFCI receptacle at the power source to protect the power cord and the unit. This GFCI will trip the circuit if it detects leakage of current from the power cord or unit.
6. To avoid personal injury, fire hazards and/or damage to the PRED1200 electrical system and power cord, do not connect or disconnect the power cord to an electrical outlet unless the motorized impeller is "OFF".

REQUIREMENTS FOR SAFE OPERATION

1. Never allow unauthorized individuals or children to operate the unit at any time.
2. Abatement Technologies urges anyone operating the PRED1200 to wear the proper personal protective equipment and follow safe work practices in accordance with federal, state, provincial and employer regulations.
3. Check the condition of power cord(s) before using them. Damaged cords can cause fatal electric shock and/or motorized impeller failure.
4. Power cord(s) should never be exposed to water, heat, sharp, or abrasive objects; in addition, they should never be kinked or crushed. Avoid tightly wrapping the cords to prevent kinking of the internal wires. Always replace damaged power cords immediately.
5. Never pull the unit by the power cord.
6. Avoid running over power cords with utility equipment and vehicles.

Important Safety Instructions

- a. **Do not operate any unit with a damaged cord or plug. Discard unit or return it to an authorized service facility for examination and/or repair.**
- b. **Do not run cord under carpeting. Do not cover cord with throw rugs, runners, or similar coverings. Do not route cord under furniture or appliances. Arrange cord away from traffic area and where it will not be tripped over.**

Caution: As with any piece of electrical equipment, always make sure that the unit is turned “OFF” prior to connecting the power cord to an electrical outlet or disconnecting it from an electrical outlet. Failure to do so will cause “arcing”, and could result in personal injury, fire hazards and/or damage to the unit. Do not disconnect the power cord from supply receptacle while the unit is operating.

Warning: To reduce risk of electrical shock, do not expose this unit to water or rain. Do not touch the electrical outlet or power cord(s) with wet hands or while standing on a wet or damp surface.

Warning: Risk of electrical shock! Can cause injury or death! Turn unit “OFF” and disconnect power cord from supply receptacle before replacing the HEPA filter and before cleaning or servicing the unit.

Warning: The PRED1200 is equipped with an automatic restart motorized impeller that will restart without warning after a temporary power interruption or recovery from a thermal overload (over-heating) condition. Keep clear of the motorized impeller at all times to reduce the risk of injury.

Warning: To reduce risk of fire or electrical shock, do not use the PRED1200 with any solid state speed control device. Do not use in a cooking area.

Caution: The PRED1200 is designed for indoor use only.

CAUTION: For General Ventilating Use Only. Do Not Use To Exhaust Hazardous Or Explosive Materials And Vapors.

Warning: Abatement Technologies air filtration systems are not intrinsically safe for use in hazardous environments. Always consult a certified industrial hygienist before using them. Do NOT use this equipment in any atmosphere that is or may be immediately dangerous to life or health (IDLH), combustible, flammable, explosive, oxygen deficient, and/or contains odors, vapors, gases or particulates that exceed permissible exposure levels. Such atmospheres may require the use of intrinsically safe equipment, specific engineering controls, and personal protective equipment in accordance with Occupational Safety and Health Administration (OSHA), Environmental Protection Agency (EPA), Canadian Standards Association (CSA), and other federal, state, provincial and local regulations.

Warning: This equipment is not classified as “intrinsically safe” and should not be used in the following hazardous locations as defined by the Underwriters Laboratories: Class I Division 1, Class I Division 2, Class I Zone 0, Class I Zone 1, Class I Zone 2, Class II Division 1, Class II Division 2, Class III Division 1, Class III Division 2. Refer to the UL web site: <http://www.ul.com/hazloc/define.htm>.

Warning: Do not use this unit near sparks, open flames or other possible sources of ignition.

PRED1200 CONTROL PANEL

1. **Speed Control Switch** - Serves as the power switch and provides a variable adjustment to the speed of the motorized impeller.
2. **Power Indicator** - Green light that indicates speed control switch is "ON" and system is connected to power source.
3. **Hour Meter** - Provides a count of the total operating hours.
4. **Filter Change Indicator - Pre-filters** – Red light that indicates excessive restriction on air intake or loading of the pre-filter(s) and that filter change procedures should be followed.
5. **Filter Change Indicator - HEPA** - Red light that indicates excessive restriction on air exhaust or loading of the HEPA filter and that filter change procedures should be followed.
6. **Circuit Breaker** - 12 amp circuit breaker that provides protection for the unit's electrical components.
7. **GFCI Receptacle** - Electrical safety device that will trip and stop the flow of electricity if leakage of current is detected from the unit or an electrical device plugged into the GFCI receptacle. The PRED1200 can supply a total of 8 amps of electrical power for additional equipment that is connected to the GFCI receptacle. Do not exceed this 8 amp limit.

Note: If the equipment connected to the GFCI receptacle draws more than a total of 8 amps, the circuit breaker on the control panel and/or the building breaker will trip. This condition can be remedied only by reducing the total amperage draw.

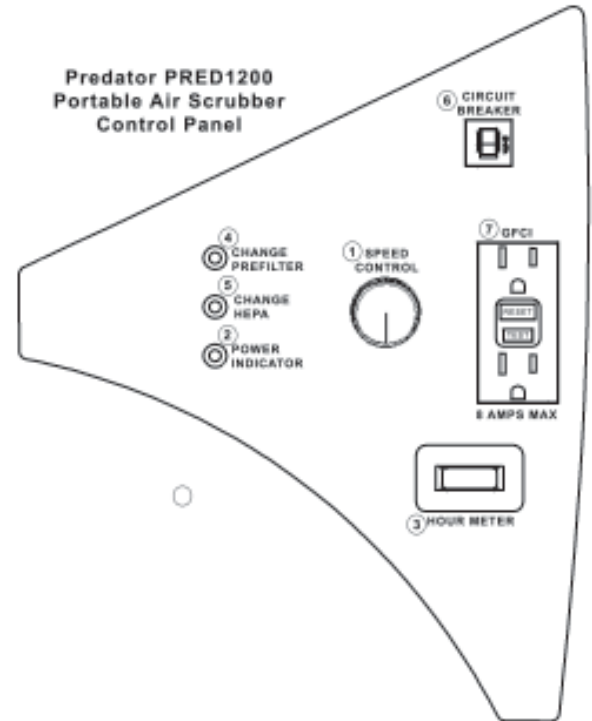

BEFORE OPERATING THE UNIT, NOTE THE FOLLOWING:

Inspect and tighten any HEPA filter retaining nuts that may have loosened during transportation. Inspect the filters for any material or structural damage prior to use and replace any damaged filters before operating the unit. When removing any filters prior to operation, always put them back in place with airflow indicator on filter housing oriented in the proper direction (if applicable).

As with any air filtration system, external airflow losses not attributable to the air filtration unit will reduce the airflow of the system. The following recommendations can minimize airflow losses created by external static resistance.

1. Always use the minimum length of ducting possible with the fewest possible number of turns and bends.
2. Rigid metal ducting creates less turbulence and consequently less airflow loss than flexible ducting. Regardless of the type of ducting used, rigid, "sweep-type", radiused connections should be used for all turns and bends.
3. If flexible ducting is used, it must be kept as taut as possible to avoid flattening.

LOCATION OF THE UNITS AND MODES OF OPERATION

1. **Negative Pressure** - used to help ensure that airborne contaminants do not escape from a contained area, by maintaining negative (lower) air pressure within that area compared to adjacent areas. This is generally accomplished by placing the unit inside the containment area and exhausting filtered air from the unit out of the area. The filtered air must be exhausted outside of the containment area, either

directly to the outdoors, or into another part of the building. To maintain negative pressure, the air exhaust must exceed the air supply by the greater of 10% or 100 CFM. To achieve this differential, the air supply volume to the area may have to be reduced. Negative pressure levels should be continuously monitored.

2. **Recirculation** - used to reduce concentrations of airborne contaminants in a room or area by continuously cleaning the air and exhausting it back into the same room or area.
3. **Positive Pressure** - used to help prevent airborne contaminants from entering a containment area, by keeping that area under positive pressure compared to adjacent spaces, so any air leakage will be an outflow of clean air, and not inflow of contaminated air. This pressure differential can be established by:
 - a. placing the unit inside the containment area, and using it to pull air into the area by attaching flex duct between the inlet collar and a location outside of the containment area.
 - b. placing the unit outside of containment area, and using it to push HEPA-filtered air into the area through flex duct attached between the outlet collar and a location inside the area.

To ensure that the proper pressure differential is maintained, the volume of HEPA-filtered air supplied to the area must be the greater of 10% or 100 CFM higher than the volume of air exhausted from it by the HVAC system. Positive pressure levels should be monitored continuously.

Important Note: Do not operate the unit unless the pre-filter(s) and HEPA filter are installed, and the filter access door and panel are in place and closed.

DAISY CHAINING

“Daisy Chaining” refers to the operation of multiple units on one circuit, with only one of the units plugged into a 120V/15A electrical power supply receptacle. Each subsequent unit is plugged into one of the GFCI receptacles on the prior unit, up to the maximum number allowed based on the amperage draw per unit. The National Electrical Code limits the total amperage draw of devices operating on one circuit to 80% of full load, which means that the total amperage draw on a 120V/15A circuit, including the unit plugged into the building electrical power supply receptacle, must not exceed 12 amps.

A total of three PRED1200 units can be “Daisy Chained” on a 15 amp circuit, including the unit plugged into the building electrical power supply receptacle.

TO START UNIT

1. Check to make sure that the Speed Control Switch is in the “OFF” position. Plug power cord into a 120 volt AC, 60Hz, 15 amp supply circuit.
2. Turn Speed Control switch clockwise past the click at the “HIGH” setting to turn power “ON”.
3. Set Speed Control switch to desired setting.

Note: Refer to the chart in this instruction manual entitled “AIRFLOW RATINGS” that lists the airflows for the PRED1200.

Note: In the event of a power failure while the unit is running, or loss of power due to any other cause, this unit’s motorized impeller will re-start when power is restored, after a brief delay.

FILTER CHANGE INDICATORS

“Change Pre-filter” light “ON” indicates one or more of the following:

1. Loaded pre-filter(s). Refer to filter change procedures.
2. Restrictions on air intake. Refer to Troubleshooting Guide.

“Change HEPA” light “ON” indicates the following:

1. Loaded HEPA filter. Refer to filter change procedures.
2. Excessive restrictions on air exhaust. Refer to Troubleshooting Guide.

FILTER REPLACEMENT

Note: Personnel responsible for changing filters, servicing units or relocating units within the facility are urged to wear the proper personal protective equipment and follow safe work practices in accordance with federal, state, provincial, and employer regulations.

Note: Filters being replaced must be disposed of in accordance with federal, state, provincial, local and facility regulations.

System airflow reduction is generally the result of filter loading, blockage of the unit's inlet or use of excessive lengths of flex duct that is connected to the inlet.

The size and concentration of airborne contaminants, temperature and humidity conditions, and duration of use determine how often filters need replacement. If the Filter Change Indicator(s) on the control panel illuminate, this indicates one or more of the following: (1) pre-filter(s) are loaded, (2) the inlet or exhaust is obstructed, (3) the flex duct, if attached to inlet or exhaust, is too long or has too many bends, and (4) the HEPA filter is loaded.

The method of determining when to replace the optional activated carbon filter is somewhat subjective. As the odor, vapor, and/or gas filtration capacity decreases, the user will begin to sense a slight odor or taste of the contaminant, indicating that the filter should be replaced.

Note: The filters are not reusable, therefore, do not attempt to clean and reuse them.

Caution: Abatement Technologies PRED1200 Portable Air Scrubber units are designed to meet or exceed standards for high efficiency air filtration equipment. Use only Abatement Technologies parts, including replacement filters. Use of non-Abatement Technologies parts and filters voids the product warranty and all performance claims.

Warning: To reduce the risk of fire, electrical shock or personal injury, always turn the PRED1200 "OFF" and disconnect the power cord from supply receptacle before replacing the HEPA filter and before cleaning or servicing the unit.

FILTER CHANGE PROCEDURE

To Change the First Stage Filter:

1. With the unit operating, turn the latch on the pre-filter access door counterclockwise (approx ½ turn), and open the door.
2. Remove the first stage filter and replace it with a new one.
3. Close the door and lock it in position by turning the latch clockwise. Make sure the door is flush against the PRED1200 cabinet before closing latch.
4. If the "Change Pre-filter" light remains "ON" after changing the first stage filter, the second stage filter should be replaced.

To Change the Second Stage Filter:

1. Open the pre-filter access door.
2. Remove the second stage filter and replace it with a new one.
3. Close the door and lock it in position.
4. If the "Change Pre-filter" light remains "ON" after changing the second stage filter, the optional third stage filter should be replaced. The light would remain "ON" only if the optional third filter is in use and has become loaded.

To Change the Optional Third Stage Filter:

1. Open the pre-filter access door.
2. Remove the third stage filter and replace it with a new one.
3. Close the door and lock it in position.

Note: If an optional Vapor-Lock® filter is being used, be sure to remove it from its poly bag before installing it in the unit. Vapor-Lock® filters are packaged in poly bags to preserve the integrity of the carbon granules.

To Change the HEPA Filter:

1. Turn the unit "OFF" and disconnect the power cord from the electrical outlet.
2. Remove the screws that hold the HEPA filter access panel in place and set the panel aside.
3. Remove the wing nuts that secure the HEPA filter retaining bracket in place, slide the bracket off the long filter retaining bolts and remove the HEPA filter.
4. Carefully place a new HEPA filter (part# H610C-99) into the cabinet, making sure that it rests on the curved section of the cabinet base, which is just behind the long, lower filter retaining bolt. The foam seal of the filter should be aligned with the exhaust outlet.
5. Place the HEPA filter retaining bracket over the retaining bolts and secure it in place with the wing nuts. Do not over-tighten the wing nuts.
6. Re-attach the HEPA filter access panel and secure it to the cabinet with its screws.

Warning: Use only Abatement Technologies pre-filters, HEPA filters, and replacement parts. Substitute parts void the warranty, jeopardize worker and environmental safety, and adversely effect engineered performance levels.

PRED1200 SPECIFICATIONS

FEATURE	PRED1200
Net weight w/filters:	70 lbs.
Shipping weight:	95 lbs.
Dimensions (LxWxH):	22"L x 24"W x 42"H
Power supply requirements:	120 volts AC, 60Hz, 15 amp circuit.
Normal operating amps:	3.5 amps or less
Motorized Impeller:	400 watt motorized impeller with thermal overload protection, auto re-set, 60 Hz, single phase.
Circuit Breaker:	12 amp
Operational sound level:	62 - 67 dBA, reading taken at 5 feet
Cabinet material:	UL94HB flame retardant resin with EPA-Registered microbial inhibitor.
Transportability:	2 each 8" solid, non-marking rubber wheels in rear and 2 ea. 360° swivel casters in front.
Pre-filter access:	Easy-operating hinged door is secured by rotating latch to protect against filter by-pass.
First stage pre-filter:	1" coarse particulate pre-filter (F621)
Second stage pre-filter:	2" pleated particulate pre-filter (H502)
Optional third stage pre-filter:	2" high capacity carbon filter (VL1002)
HEPA filter:	Tested and certified to an efficiency of 99.97% or higher against 0.3 micron size particles. (H610C-99)
Patent:	Patented - U.S. Design Patent No. D572,356

Note: Specifications subject to change without notice.

AIRFLOW RATINGS

	Lowest Speed	Highest Speed
Predator 1200	300 CFM	900 CFM

Note: Airflow ratings estimates are based on factory and independent testing @ 120 VAC with an air straightener and a traverse of readings taken with a computing vane-anemometer. Actual results may vary for various reasons, including motor and blower and HEPA filter tolerances. Factors such as filter loading, reduced voltage to the motor, and inlet and outlet ducting will reduce airflow. Use these ratings as a general guideline only.

TROUBLESHOOTING GUIDE

PROBLEM	POSSIBLE CAUSE	SOLUTION
NO RESPONSE WHEN THE POWER IS TURNED "ON".	POWER CORD UNPLUGGED. DEFECTIVE POWER CORD. TRIPPED CIRCUIT BREAKER. TRIPPED GROUND FAULT CIRCUIT INTERRUPTER. THERMAL OVERLOAD ON THE MOTORIZED IMPELLER HAS TRIPPED.	PLUG POWER CORD FIRMLY INTO ELECTRICAL OUTLET IN WALL. CHECK ALL CONNECTIONS AND CONDITION OF ALL CORDS. DO NOT OPERATE WITH DAMAGED POWER CORD(S). RESET BREAKER FOR BUILDING. RESET 12 AMP BREAKER ON CONTROL PANEL. RESET GFCI ON CONTROL PANEL AND/OR AT POWER SOURCE. TURN UNIT "OFF", WAIT 30 MINUTES AND RESTART UNIT.
CIRCUIT BREAKER ON CONTROL PANEL OR BUILDING "TRIPS".	OVERLOADED CIRCUIT.	UNPLUG ANY ADDITIONAL EQUIPMENT CONNECTED TO THE GFCI RECEPTACLE. RESET CIRCUIT BREAKER.
FILTER CHANGE INDICATOR(S) "ON".	LOADED FILTERS. EXCESSIVE RESTRICTIONS ON INTAKE OR EXHAUST. CARBON FILTER HAS NOT BEEN REMOVED FROM POLYBAG.	CHANGE IN ACCORDANCE WITH OPERATING INSTRUCTIONS. REDUCE BENDS, LENGTH OF FLEX DUCT OR ELIMINATE RESTRICTIONS. REMOVE CARBON FILTER FROM POLYBAG.

Note: If the unit does not start or malfunctions after carefully following the **Troubleshooting Guide**, call Abatement Technologies service department at 800-634-9091 (U.S.) or 905-871-4720 (Canada) for assistance.

COMPONENT REPLACEMENT AND CARE OF THE UNIT

Warning: To reduce the risk of fire, electrical shock or personal injury, always turn the unit "OFF" and disconnect power cord from supply receptacle before removing the control panel, replacing the HEPA filter and before cleaning or servicing the unit. The PRED1200 is equipped with an automatic restart motorized impeller that will restart without warning after a temporary power interruption or recovery from a thermal overload (over-heating) condition. Keep clear of the motorized impeller at all times to reduce the risk of injury.

Occasionally a defective component will cause the unit to operate improperly or not at all. Any electrical component can fail. Refer to the Wiring Diagrams and Wiring Schematics to diagnose the failure of any component. Diagnostics should only be performed by a technician qualified to service electrical equipment.

The unit is plastic and should be cleaned with a damp cloth or a water-based cleaner/sanitizer. Do not use harsh chemicals, solvents or detergents to clean the unit.

Warning: Keep electrical components dry as their exposure to liquids poses a safety hazard and can damage components.

CERTIFICATION OF ROOM AIR FILTRATION UNITS

The Abatement Technologies room air filtration units have been tested by Intertek Testing Services (ITS) and are ETL and ETLC (Canada) listed for electrical safety.

ITS is accredited by the U.S. Occupational Safety and Health Administration (OSHA) as a Nationally Recognized Testing Laboratory (NRTL).

LIMITED WARRANTY

Abatement Technologies, Inc (ATI) warrants that goods sold to the original user shall be free from defects in material and workmanship for a period of 1 year, except such as are commercially acceptable. This warranty does not include useful filter life. The plastic cabinet has a lifetime warranty period for the original user. **ATI does not warrant that the goods sold are merchantable or fit for any particular purpose. ATI makes no warranties other than as stated in this paragraph. All other warranties, guaranties, or representations, express or implied, by operation of law or otherwise, are expressly disclaimed.** Goods found by ATI to be defective or not to conform to specification shall upon return be replaced or repaired by ATI without any additional charges, or, at ATI's option, ATI may refund the purchase price of such goods. ATI will pay return transportation charges on returned goods not exceeding the transportation charges applicable to shipment from original destination unless the returned goods are free from defect and conform to specifications. Returned goods which are found by ATI to be free from defect and to conform to specifications shall be held for Purchaser's shipping instructions, which instructions Purchaser shall furnish promptly upon request. **ATI's liability shall in no event extend beyond replacement, repair or refund of the purchase price and ATI shall not be liable under any circumstances for special, contingent or consequential damages, nor for loss, damages, or expenses directly or indirectly arising from the use of the goods, including without limitation, warehousing, labor, handling and service charges, die, equipment, or machine breakage, nor for costs, lost profits or loss of good will. The use of substitute, non-ATI parts and/or filters, in any ATI product, voids all warranties and performance claims. The remedies set forth herein are exclusive.**

For warranty information and assistance contact Abatement Technologies' Customer Service Department at 800-634-9091 (U.S.) or 905-871-4720 (Canada.)

Abatement Technologies' PRED1200 high-efficiency air filtration units are originally equipped with true HEPA (High Efficiency Particulate Air) filters designed to maximize the performance of the equipment, and to meet the following industry standards:

Institute of Environment Sciences and Technology

IEST-RP-CC001.3 (Type A HEPA and ULPA Filters)

IEST-RP-CC021.1 (Testing HEPA and ULPA Filter Media)

Underwriters Laboratories

UL900, Class II (Flammability Specifications)

100% Efficiency Tested

Abatement Technologies HEPA filters are individually tested and certified to ensure that the completed filter provides an overall minimum efficiency of 99.97% when challenged by a thermally generated test aerosol, 0.3-microns in size, in accordance with IEST-RP-CC001.3.

Predator 1200 Control Panel Wiring Diagram

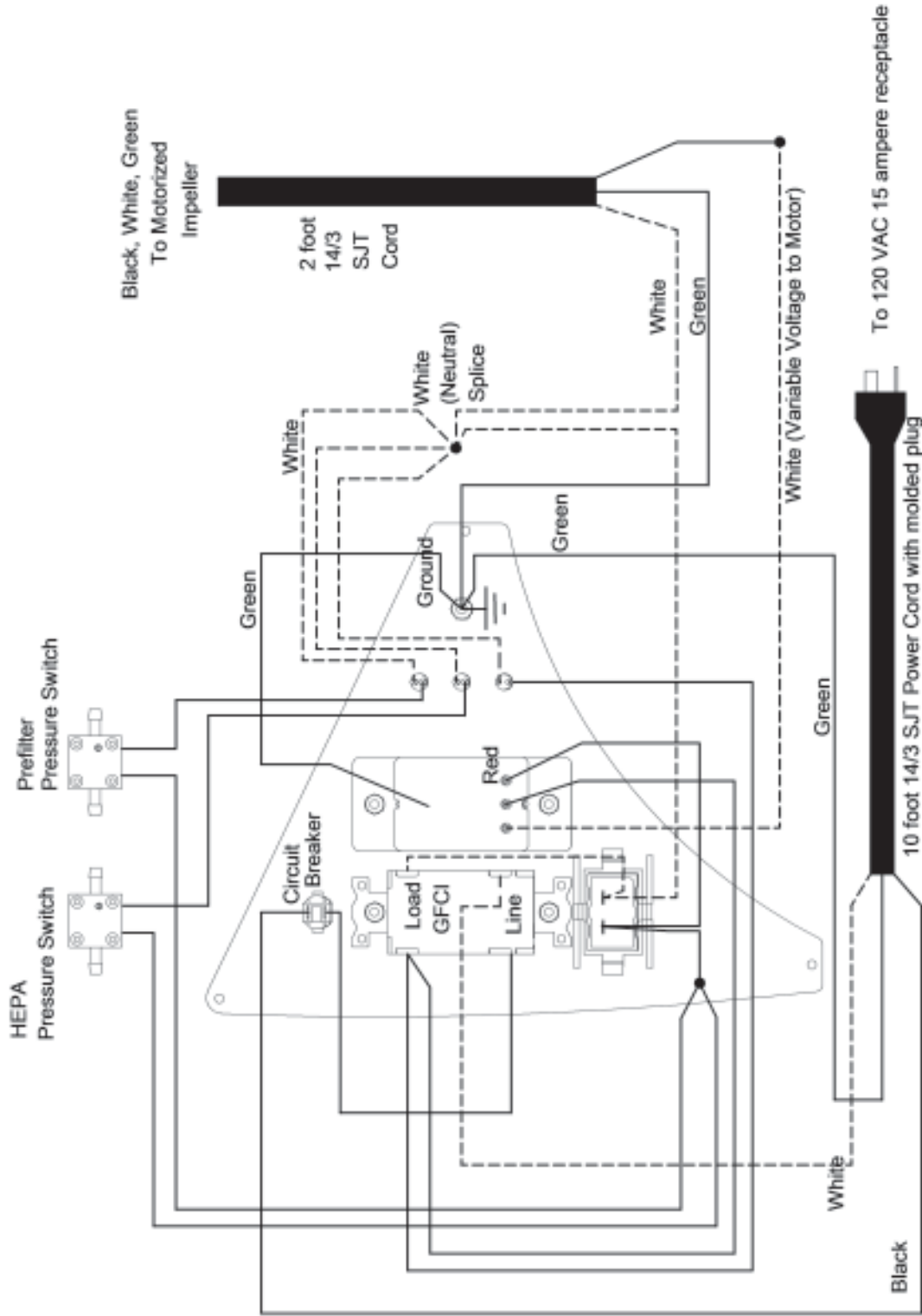

rev.C

Predator 1200 Motorized Impeller Wiring Diagram

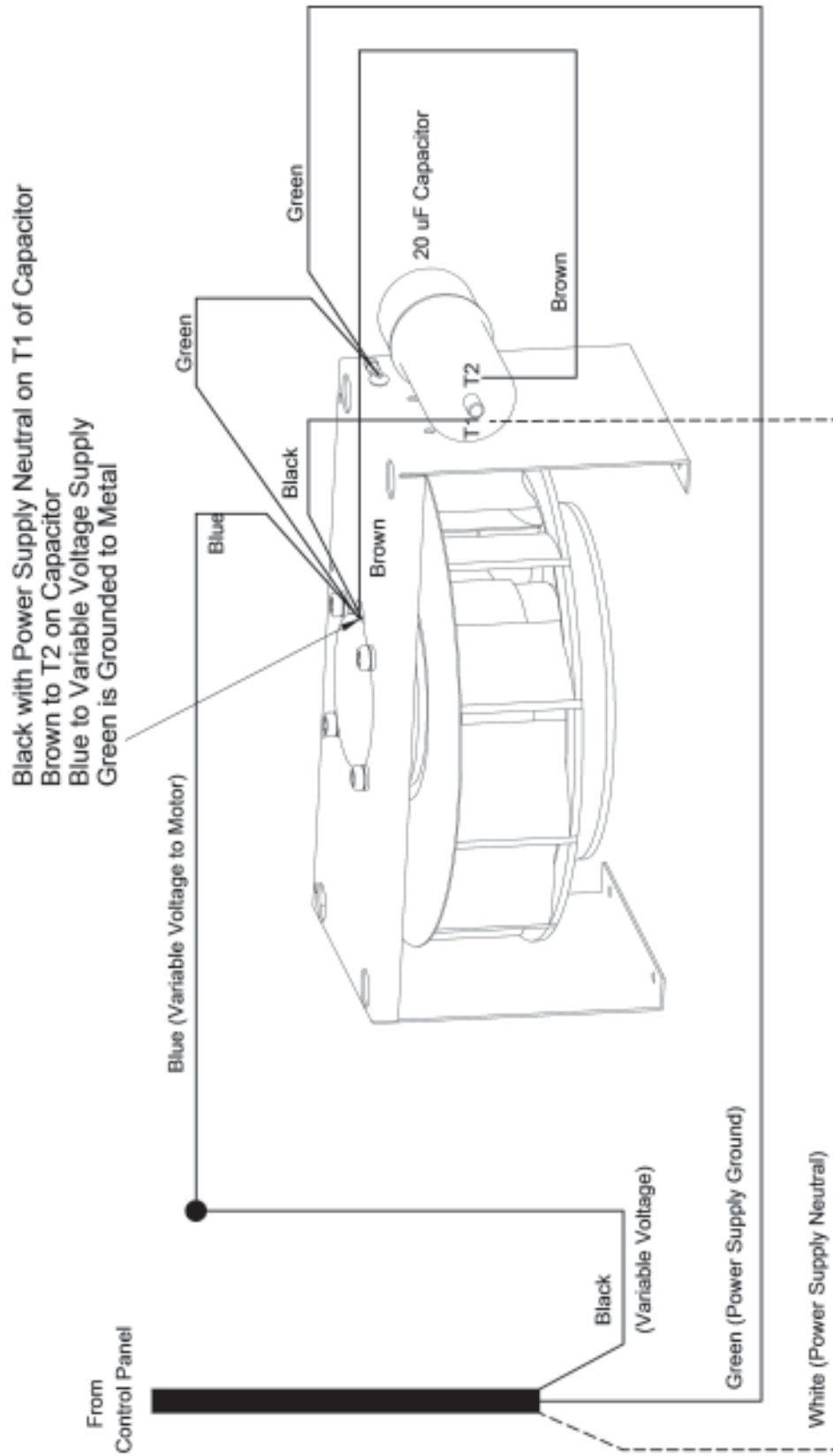

rev. C

Predator 1200 Wiring Schematic

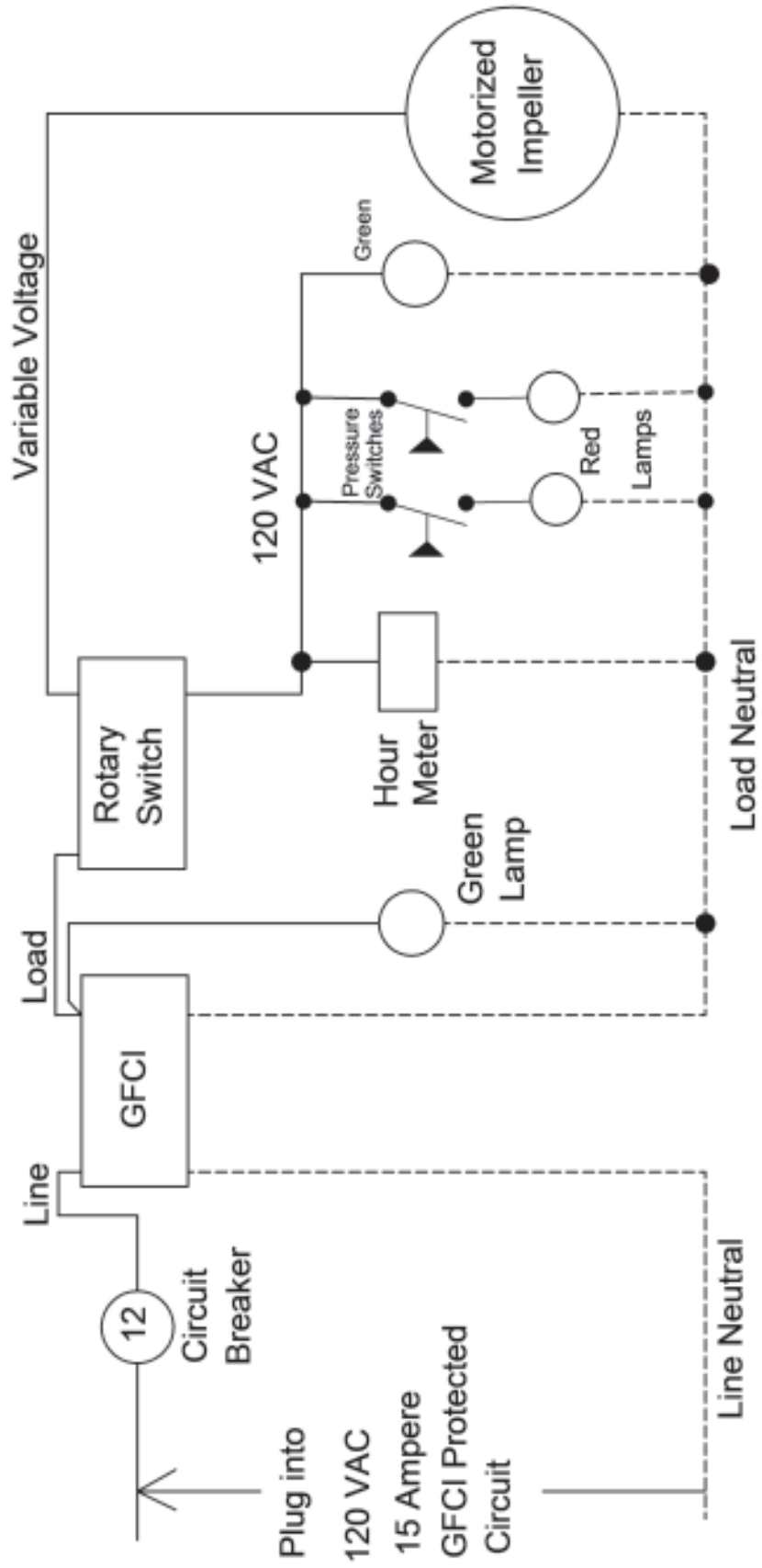

rev. C