

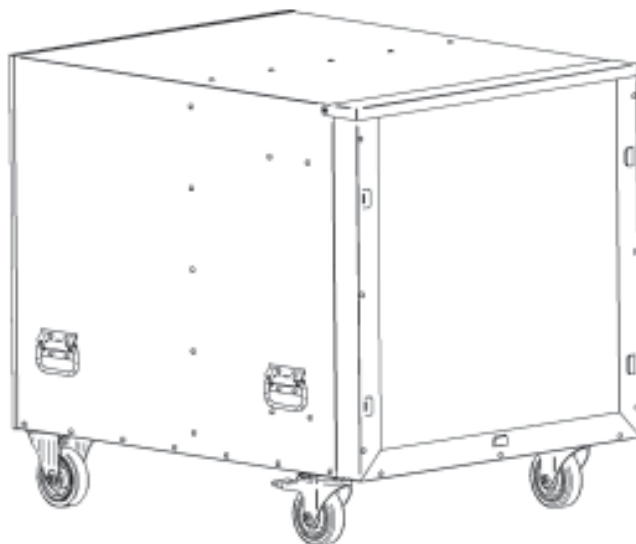

HEPA-AIRE H2000LA

INSTRUCTION MANUAL



Abatement Technologies, Inc./Asbestos Abatement Division

Abatement Technologies, Inc.
Georgia, USA
800-634-9091

Abatement Technologies, Ltd.
Ontario, Canada
905-871-4720

www.abatement.com

HEPA-AIRE Portable Air Filtration Unit Model: H2000LA

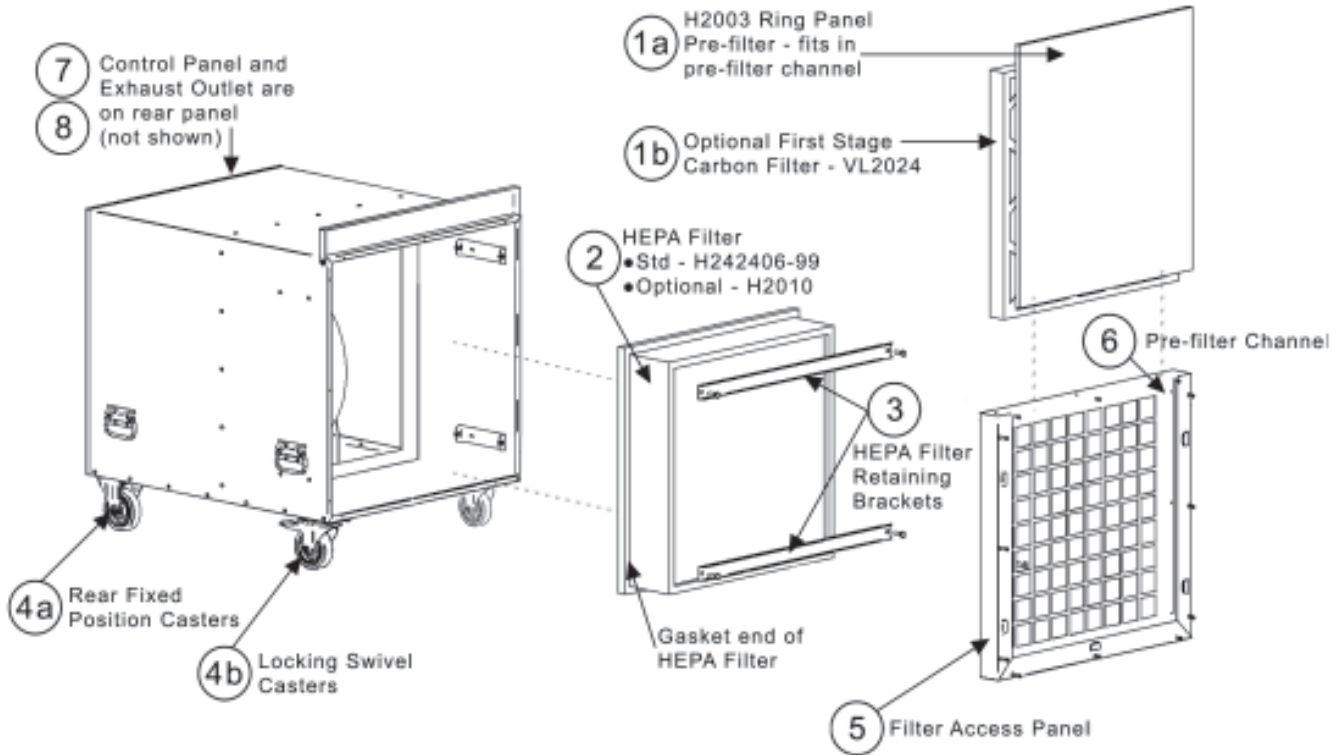

1. First Stage:
 - a. 1" coarse/particulate ring panel-style pre-filter (P/N H2003)
 - b. Optional 2" high capacity carbon filter (P/N VL2024)
2. Final Stage:
 - Standard: 6" deep, 99.97% HEPA filter (P/N H242406-99)
 - Optional: 11 1/2" deep, 99.97% HEPA filter (P/N H2010)
3. HEPA filter retaining brackets
4. Casters:
 - a. 2 each 4" fixed position casters
 - b. 2 each 4" 360° swivel casters with locking feature
5. Filter access panel
6. Pre-filter channel
7. Control panel - on rear panel of unit
8. Exhaust outlet - on rear panel of unit

HEPA-AIRE® Portable Air Filtration Unit
Model: H2000LA
Instruction Manual

© Abatement Technologies 2008 All Rights Reserved. No reproduction of any portion of this work is permitted without the express written permission of Abatement Technologies, Inc.

READ AND SAVE THESE INSTRUCTIONS!

- Note:** 1. **Read and understand all operating instructions before using the H2000LA Portable Air Filtration Unit.**
2. **Save this manual for future reference.**

This instruction manual provides important information on the use of the HEPA-AIRE Portable Air Filtration Unit - model H2000LA. These instructions must be carefully followed in order to operate the unit safely and correctly. If there are any questions regarding the use of the unit, please contact Abatement Technologies immediately at 800-634-9091 U.S. or 905-871-4720 Canada.

Abatement Technologies strongly urges users of air filtration unit and related accessories to follow the most recent guidelines and/or standards published by the Occupational Safety and Health Administration, Environmental Protection Agency, and all other federal, state, provincial and local regulations.

Note: The U.S. Environmental Protection Agency's publication "Guidance for Controlling Asbestos-Containing Materials in Buildings", EPA 560/5-85-024, includes helpful information on air filtration systems. Abatement Technologies strongly urges anyone performing asbestos abatement to read the most recent edition of this EPA publication before using any air filtration system.

GENERAL INFORMATION

The H2000LA is a multi-use air filtration machine, equipped with a pre-filter and a HEPA filter that are capable of filtering many airborne contaminants. An optional carbon pre-filter for capturing low concentrations of odors, vapors, gases, and volatile organic compounds, collectively known as OVG, is also available.

Types of contaminants captured by particulate pre-filters, HEPA filter, or carbon filters:

- | | | |
|----------------|---------------------------|--|
| • Dirt | • Lung-damaging particles | • Low concentrations of OVG |
| • Dust | • Metal fumes | • Low concentrations of Volatile Organic Compounds (VOC) |
| • Drywall dust | • Smoke | • Unpleasant nuisance odors |
| • Saw dust | • Mold and fungal spores | |

Note: To capture low concentrations of OVG, a Vapor-Lock® carbon filter must be used.

The H2000LA is capable of providing particulate and odor, vapor, gas filtration with final stage filtration through a High Efficiency Particulate Air (HEPA) filter. The unit incorporates a series of particulate filters which successively remove larger size to smaller size particles from the air. In addition to providing HEPA filtration, the H2000LA is primarily used in a negative pressure or recirculation mode. A negative pressure condition is created in order to confine contaminated airborne particles. This condition exists when the static pressure inside the room containing the unit is lower relative to the pressure of the environment outside the room. The static pressure differential is created and maintained by continuously exhausting air out of a given room at a faster rate than air enters the room from all other sources. In the recirculation mode, all of the filtered air is exhausted back into the room containing the unit.

Standard Air Cleaning Stages (filters supplied with the unit)

The H2000LA comes equipped with two progressively efficient particulate filters. The first stage filter is mounted in the pre-filter channel and the final stage HEPA filter is located inside the cabinet:

- First stage: 1" deep, coarse particulate ring panel-style pre-filter (H2003) is designed to capture particles 100 microns or larger.
- Final stage: 6" deep HEPA filter (H242406-99) is tested and certified to capture at least 99.97% (9,997 out of 10,000) 0.3-micron particles.

Note: The particulate filters in the H2000LA do **not** remove odors, vapors or gases, including volatile organic compounds.

Optional Filters (must be purchased separately)

There are two optional filters that can be used in the H2000LA:

- 2" deep, Vapor-Lock® pleated high-capacity carbon filter (VL2024) for capturing OVG and particles 10 microns or larger. The VL2024 mounts in the pre-filter channel.
- 11½" deep, fiberboard frame HEPA filter (H2010) is tested & certified to capture at least 99.97% of 0.3 micron particles.

The 2" deep Vapor-Lock® pleated high-capacity carbon filter can be used to reduce airborne OVG by chemically bonding the OVG molecules to the surface area of the carbon granules, via a process known as adsorption.

Effective carbon adsorption is dependent upon the amount of carbon & exposed carbon granule surfaces, and the dwell (contact) time the OVG molecules have with the carbon granules. Operating the unit at low speed to increase dwell time can therefore improve OVG adsorption, though it is highly unlikely that all of the OVG will be removed in one pass of air through the unit. Operating the unit in the recirculation mode can increase effectiveness, by exposing OVG particles to multiple passes through the Vapor-Lock® filter.

It is almost impossible to provide accurate estimates to two commonly asked questions: "how much time will it take to capture all of the OVG?", and "how do I know when a carbon filter should be replaced?" Unfortunately, unknown factors, such as concentration levels, fresh-air intake volume, temperature, and humidity prevent establishment of any more accurate 'rule of thumb' than one's sense of smell. Since off-gassing of adsorbed OVG can occur when the adsorption capacity of the filter is reached, replace the carbon filter as soon as odor breakthrough is sensed. More detailed information on carbon adsorption can be found in an article titled: "**Activated Carbon: How Is It Used? How Does It Work?**", which can be found on the Links and Articles page of the "Asbestos Abatement Contractors" section of the Abatement Technologies website, www.abatement.com.

TO DETERMINE THE REQUIRED NUMBER OF PORTABLE AIR FILTRATION UNITS

Note: The "Asbestos Abatement Contractors" section of the Abatement Technologies website, www.abatement.com, includes a handy Air Change Calculator for the H2000LA. This calculator provides users with a simple way to determine how many units are needed to provide a given number of air changes per hour (ACH) in any size containment area, and eliminates the need for user calculations. Simply enter the dimensions of the containment area, the ACH required, and select a built-in safety factor (SF), to compensate for potential losses due to filter loading, inlet and exhaust collars, ducting, etc. (Please note that use of a SF is recommended, but not required). The calculator does the rest.

To determine the number of units required without using the Air Change Calculator, proceed as follows:

1. Calculate the volume inside containment (V), in cubic feet, by multiplying the length of the area (L) x the width of the area (W) x the ceiling height (H), in feet.
2. Determine the minimum ACH required in the job specification.
3. Select a safety factor (SF). Most users build-in between 10% (SF = 1.1) and 25% (SF = 1.25), or more. If you don't wish to use a SF, proceed to Step 4.
4. Calculate the minimum total airflow required (Total CFM), as follows:
$$\text{Total CFM} = (V \times \text{ACH} \times \text{SF}) \div 60.$$
5. # Units Required = Total CFM ÷ CFM rating for the Unit.
6. Always round up to the next whole number. For example, if the minimum requirement is 2.1 units, 3 units are recommended, not 2.

Example 1:

How many 1,950 CFM units are needed to provide at least 6 ACH in a 35' x 30' x 10' containment area, with a 20% safety factor?

$$V = 35 \times 30 \times 10 = 10,500 \text{ Cubic Feet}$$

$$\text{Total CFM} = (10,500 \times 6 \times 1.2) \div 60 = 1,260 \text{ CFM}$$

$$\text{Minimum \# Units Req'd} = 1,260 \text{ CFM} \div 1,950 \text{ CFM (airflow of unit)} = 0.65 = \underline{\mathbf{1 \text{ Unit Required}}}$$

Example 2:

How many 1,950 CFM units are needed to provide at least 5 ACH in a 45' x 50' x 10' containment area, with a 25% safety factor?

$$V = 45 \times 50 \times 10 = 22,500 \text{ Cubic Feet}$$

$$\text{Total CFM} = (22,500 \times 5 \times 1.25) \div 60 = 2,344 \text{ CFM}$$

$$\text{Minimum \# Units Req'd} = 2,344 \div 1,950 = 1.21 = \underline{\mathbf{2 \text{ Units Required}}}$$

Note: This example illustrates the importance of a Safety Factor. If no SF were used, only 1,875 CFM (1 unit) would be required.

H2000LA TRANSPORT

Note: The H2000LA should be transported in the horizontal position. If extremely poor road conditions exist or excessive shock and vibration are expected, take precautionary measures by padding the unit to provide impact absorption during transport.

Caution: Always use caution when moving the H2000LA inside a building or home. The unit weighs 117 pounds with the H242406-99 HEPA filter and 144 pounds with the H2010 HEPA filter. Older structures with weakened floors or staircases may require special considerations for safe transport.

ELECTRICAL REQUIREMENTS

1. The H2000LA unit requires a minimum of 110 volts AC, 60 Hz to operate properly; however, maximum airflow performance requires 120 volts AC, 60 Hz.
2. Due to momentary start-up current surge, the unit requires a 15 amp circuit that is free of other loads.
3. If the unit is connected to a circuit that is protected by fuses, use time delay fuses.
4. Extension cords used for the H2000LA must be UL-listed, heavy duty No. 12/3 AWG industrial grade 3-wire type. Use of larger numerical gauge (lower capacity wire) power cord(s) may result in electrical shock, fire hazards and/or damage to unit. The cord(s) must be in good condition and in continuous lengths (no splicing) and should not exceed a total of 50 feet in length. Make certain that any extension cords used do not reduce power to the unit to less than 110 volts. Use of a voltmeter to confirm adequate voltage is recommended.

5. Check to ensure that any circuit to which the unit is connected is protected by a 15 ampere circuit breaker.
6. The H2000LA should be connected to a three-prong, properly grounded electrical outlet equipped with a Ground Fault Circuit Interrupt (GFCI) device. A GFCI is an electrical safety device that will trip the circuit and stop the flow of electricity if leakage of current is detected.
Important Note: The H2000LA should be plugged into a GFCI receptacle at the power source to protect the power cord and the unit. This GFCI will trip the circuit if it detects leakage of current from the power cord or unit.
7. To avoid personal injury, fire hazards and/or damage to the H2000LA electrical system and power cord, do not connect or disconnect the power cord to an electrical outlet unless the motor is “OFF” (middle position of Motor Speed Switch).

REQUIREMENTS FOR SAFE OPERATION

1. Never allow unauthorized individuals or children to operate the unit at any time.
2. Abatement Technologies urges anyone operating the H2000LA to wear the proper personal protective equipment and follow safe work practices in accordance with federal, state, provincial and employer regulations.
3. Check the condition of power cord(s) before using them. Damaged cords can cause fatal electric shock and/or motor failure.
4. Power cord(s) should never be exposed to water, heat, sharp, or abrasive objects; in addition, they should never be kinked or crushed. Avoid tightly wrapping the cords to prevent kinking of the internal wires. Always replace damaged power cords immediately.
5. Never pull the unit by the power cord.
6. Avoid running over power cords with utility equipment and vehicles.

Important Safety Instructions

- a. **Do not operate any unit with a damaged cord or plug. Discard unit or return it to an authorized service facility for examination and/or repair.**
- b. **Do not run cord under carpeting. Do not cover cord with throw rugs, runners, or similar coverings. Do not route cord under furniture or appliances. Arrange cord away from traffic area and where it will not be tripped over.**

Caution: As with any piece of electrical equipment, always make sure that the unit is turned “OFF” prior to connecting the power cord to an electrical outlet or disconnecting it from an electrical outlet. Failure to do so will cause “arcing”, and could result in personal injury, fire hazards and/or damage to the unit. Do not disconnect the power cord from supply receptacle while the unit is operating.

Warning: To reduce risk of electrical shock, do not expose this unit to water or rain. Do not touch the electrical outlet or power cord(s) with wet hands or while standing on a wet or damp surface.

Warning: Risk of electrical shock! Can cause injury or death! Turn unit “OFF” and disconnect power cord from supply receptacle before replacing the HEPA filter and before cleaning or servicing the unit.

Warning: The H2000LA is equipped with an automatic restart motor and blower assembly that will restart without warning after a temporary power interruption or recovery from a thermal overload (over-heating) condition. Keep clear of the motor and blower assembly at all times to reduce the risk of injury.

Warning: To reduce risk of fire or electrical shock, do not use the H2000LA with any solid state speed control device. Do not use in a cooking area.

Caution: The H2000LA is designed for indoor use only.

CAUTION: For General Ventilating Use Only. Do Not Use To Exhaust Hazardous Or Explosive Materials And Vapors.

Warning: Abatement Technologies air filtration systems are not intrinsically safe for use in hazardous environments. Always consult a certified industrial hygienist before using them. Do NOT use this equipment in any atmosphere that is or may be immediately dangerous to life or health (IDLH), combustible, flammable, explosive, oxygen deficient, and/or contains odors, vapors, gases or particulates that exceed permissible exposure levels. Such atmospheres may require the use of intrinsically safe equipment, specific engineering controls, and personal protective equipment in accordance with Occupational Safety and Health Administration (OSHA), Environmental Protection Agency (EPA), Canadian Standards Association (CSA), and other federal, state, provincial and local regulations.

Warning: This equipment is not classified as “intrinsically safe” and should not be used in the following hazardous locations as defined by the Underwriters Laboratories: Class I Division 1, Class I Division 2, Class I Zone 0, Class I Zone 1, Class I Zone 2, Class II Division 1, Class II Division 2, Class III Division 1, Class III Division 2. Refer to the UL web site: <http://www.ul.com/hazloc/define.htm>.

Warning: Do not use this unit near sparks, open flames or other possible sources of ignition.

CONTROL PANEL COMPONENTS

1. **Power Cord** - Hardwired, 10 foot power cord for connection to electrical outlet.
2. **Motor Speed Switch** - Three position switch, “HIGH”, “OFF” (middle position of switch), and “LOW”, that controls the speed of the motor.
3. **Filter Change Indicator** - Amber light that indicates excessive restriction on intake or loading of the filter(s) and that filter change procedures should be followed. Check the Filter Loading Indicator when the unit is operating on “HIGH” speed.
4. **Audio Alarm Activation Switch** - activates and deactivates the Filter Change Audio Alarm.
Note: The unit is equipped with a filter change audio alarm that is mounted inside the cabinet. When this alarm sounds it is indicating excessive restriction on intake or loading of the filter(s) and that filter change procedures should be followed
5. **Filter Status Gauge** - indicates total system pressure increases in inches of water column (WC) due to filter loading and/or other airflow restrictions.

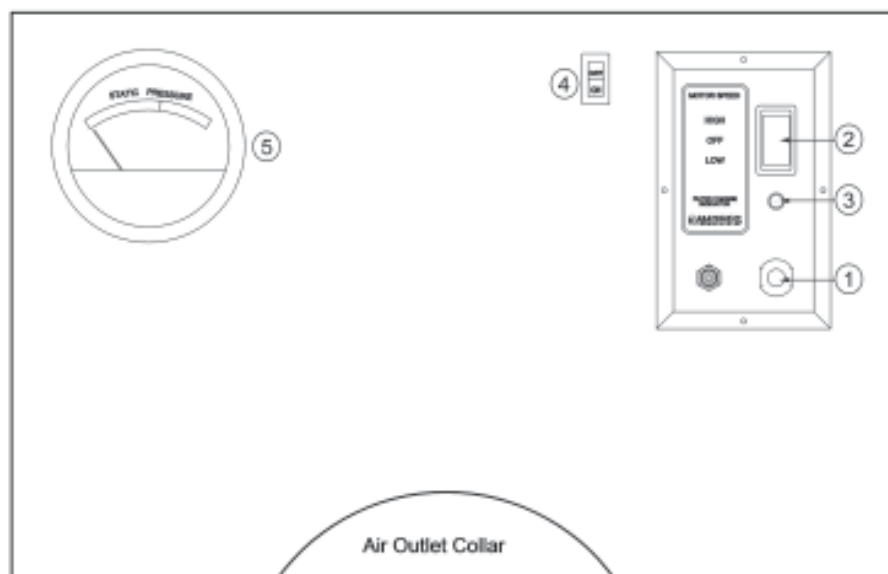

BEFORE OPERATING THE UNIT, NOTE THE FOLLOWING:

Assemble the 4 casters to the bottom of the H2000LA cabinet. Refer to Figure A. The casters are packed inside a separate box.

Inspect and tighten any HEPA filter retaining bolts that may have loosened during transportation. Inspect the filters for any material or structural damage prior to use and replace any damaged filters before operating the unit. When removing any filters prior to operation, always put them back in place with airflow indicator on filter housing oriented in the proper direction (if applicable).

As with any air filtration system, external airflow losses not attributable to the air filtration unit will reduce the airflow of the system. The following recommendations can minimize airflow losses created by external static resistance.

1. Always use the minimum length of ducting possible with the fewest possible number of turns and bends.
2. Rigid metal ducting creates less turbulence and consequently less airflow loss than flexible ducting. Regardless of the type of ducting used, rigid, "sweep-type", radiused connections should be used for all turns and bends.
3. If flexible ducting is used, it must be kept as taut as possible to avoid flattening.

LOCATION OF THE UNIT AND MODES OF OPERATION

1. **Negative Pressure** - used to help ensure that airborne contaminants do not escape from a contained area, by maintaining negative (lower) air pressure within that area compared to adjacent areas. This is generally accomplished by placing the unit inside the containment area and exhausting filtered air from the unit out of the area. The filtered air must be exhausted outside of the containment area, either directly to the outdoors, or into another part of the building. To maintain negative pressure, the air exhaust must exceed the air supply by the greater of: 10% or 100 CFM. To achieve this differential, the air supply volume to the area may have to be reduced. Negative pressure levels should be continuously monitored.
2. **Recirculation** - used to reduce concentrations of airborne contaminants in a room or area by continuously cleaning the air and exhausting it back into the same room or area.
3. **Positive Pressure** - used to help prevent airborne contaminants from entering a containment area, by keeping that area under positive pressure compared to adjacent spaces, so any air leakage will be an outflow of clean air, and not inflow of contaminated air. This pressure differential can be established by:
 - a. placing the unit inside the containment area, and using it to pull air into the area by attaching flex duct between the inlet collar and a location outside of the containment area.
 - b. placing the unit outside of containment area, and using it to push HEPA-filtered air into the area through flex duct attached between the outlet collar and a location inside the area.

To ensure that the proper pressure differential is maintained, the volume of HEPA-filtered air supplied to the area must be the greater of 10% or 100 CFM higher than the volume of air exhausted from it by the HVAC system. Positive pressure levels should be monitored continuously.

Important Note: Do not operate the unit unless the pre-filter and HEPA filter are installed and the filter access panel is in place.

TO START UNIT

1. Check to make sure that the Motor Speed switch is in the “OFF” (middle) position. Plug power cord into a 120 volt AC, 60 Hz, 15 amp supply circuit.
2. Set the Motor Speed switch to the “HIGH” or “LOW” position.
Note: Refer to the chart in this instruction manual entitled “AIRFLOW RATINGS” that lists the airflows corresponding to the various speeds for the H2000LA.

Note: In the event of a power failure while the unit is running or loss of power due to any other cause, this unit’s motor will re-start when power is restored.

FILTER CHANGE INDICATOR

If the Filter Change Indicator light turns “ON”, the Filter Change Audio Alarm sounds, and/or the Filter Status Gauge displays a reading of 1.7" WC or higher, this indicates one or more of the following:

1. Loaded filter(s). Refer to filter change procedures.
2. Restrictions on air intake. Refer to Troubleshooting Guide.

Note: The Filter Change Audio Alarm can be deactivated by turning the Audio Alarm Activation Switch “OFF”.

FILTER REPLACEMENT

Note: Personnel responsible for changing filters, servicing unit or relocating unit within the facility are urged to wear the proper personal protective equipment and follow safe work practices in accordance with federal, state, provincial, and employer regulations.

Note: Filters being replaced must be disposed of in accordance with federal, state, provincial, local and facility regulations.

System airflow reduction is generally the result of filter loading, blockage of the unit’s inlet or use of excessive lengths of flex duct that is connected to the inlet.

The size and concentration of airborne contaminants, temperature and humidity conditions, and duration of use determine how often filters need replacement. If the Filter Change Indicator light turns “ON”, the Filter Change Audio Alarm sounds, and/or the Filter Status Gauge displays a reading of 1.7" WC or higher, this indicates one or more of the following: (1) pre-filter is loaded, (2) the inlet is obstructed, (3) the flex duct, if attached to inlet, is too long or has too many bends, and (4) the HEPA filter is loaded.

The method of determining when to replace the optional activated carbon filter is somewhat subjective. As the odor, vapor, and/or gas filtration capacity decreases, the user will begin to sense a slight odor or taste of the contaminant, indicating that the filter should be replaced.

Note: The filters are not reusable, therefore, do not attempt to clean and reuse them.

Caution: Abatement Technologies H2000LA Portable Air Filtration Unit is designed to meet or exceed standards for high efficiency air filtration equipment. Use only Abatement Technologies parts, including replacement filters. Use of non-Abatement Technologies parts and filters voids the product warranty and all performance claims.

Warning: To reduce the risk of fire, electrical shock or personal injury, always turn the unit “OFF” and disconnect the power cord from supply receptacle before replacing the HEPA filter and before cleaning or servicing the unit.

FILTER CHANGE PROCEDURE

To Change the First Stage Filter:

1. With the unit operating, remove the first stage filter from the pre-filter channel and replace it with a new one.
2. If the (a) Filter Change Indicator light remains "ON" (b) Filter Change Audio Alarm sounds, and/or (c) Filter Status Gauge displays a reading of 1.7" WC or higher after changing the first stage filter, the HEPA filter should be replaced.

Note: If an optional Vapor-Lock® filter is being used, be sure to remove it from its poly bag before installing it in the unit. Vapor-Lock® filters are packaged in poly bags to preserve the integrity of the carbon granules.

To Change the HEPA Filter (H242406-99 or optional H2010)

1. Turn the unit "OFF" and disconnect the unit's power cord from the electrical outlet.
2. Remove the first stage filter from the pre-filter channel.
3. Remove the screws that secure the filter access panel to the unit's cabinet and set the panel aside.
4. Remove the bolts that secure the HEPA filter retaining brackets in place (remove the lower bracket first, then the top bracket), set the brackets aside, and remove the HEPA filter from the cabinet.
5. Carefully install a new HEPA filter (part# H242406-99 or H2010) inside the cabinet, gasketed end first. Ease the filter into the cabinet until it is flush against its sealing surface. For reference purposes, the top panel of the H242406-99 filter has various labels affixed to it and the rear of the filter is the gasketed end.
6. Re-attach the HEPA filter retaining brackets to secure the filter in its proper position. The top bracket should be re-attached first, then the bottom bracket. The bolts should be snug but not over-tightened.

Note: The HEPA filter is delicate and should be handled with care. When removing or re-attaching the HEPA filter retaining brackets, do not touch the filter media; otherwise, damage to the filter and leakage of contaminated air could result.

7. Re-attach the filter access panel to the cabinet and re-install the first stage filter.

Warning: Use only Abatement Technologies pre-filters, HEPA filters, and replacement parts. Substitute parts void the warranty, jeopardize worker and environmental safety, and adversely effect engineered performance levels.

HEPA-AIRE H2000LA SPECIFICATIONS

FEATURE	H2000LA
Net weight w/ filters:	117 lbs. with H242406-99 HEPA; 144 lbs. with H2010 HEPA.
Shipping weight:	134 lbs. with H242406-99 HEPA; 161 lbs. with H2010 HEPA.
Dimensions - LxWxH:	32 1/4" x 25 1/8" x 29 3/4".
Power supply requirements:	120 volts AC, 60Hz, 15 amp circuit.
Normal operating amps:	8 amps or less.
Motor:	0.90 HP, 2 speed motor with thermal overload protection, auto re-set, 60 HZ, single phase.
Operational sound level:	High speed: 73 dBA at intake & sides, 83 dBA at exhaust. Low speed: 68 dBA at intake & sides, 77 dBA at exhaust. Readings taken at a distance of 5 feet.
Cabinet material:	.040" thick galvanized steel.
Transportability:	2 each removable 4", 360° swivel casters with locking feature. 2 each removable 4", fixed position casters.
First stage filter:	1" coarse particulate ring panel-style pre-filter (H2003).
Optional first stage filter:	2" high capacity carbon filter (VL2024).
HEPA filter:	Tested and certified to an efficiency of 99.97% or higher against 0.3 micron size particles (H242406-99).
Optional HEPA filter:	Tested and certified to an efficiency of 99.97% or higher against 0.3 micron size particles (H2010).

Note: Specifications subject to change without notice.

AIRFLOW RATINGS

	HIGH Speed	LOW Speed
H2000LA	1,950 CFM	1,300 CFM

Note: Airflow ratings estimates are based on factory and independent testing @ 120 VAC with an air straightener and a traverse of readings taken with a computing vane-anemometer. Actual results may vary for various reasons, including motor and blower and HEPA filter tolerances. Factors such as filter loading, reduced voltage to the motor, and inlet and outlet ducting will reduce airflow. Use these ratings as a general guideline only.

TROUBLESHOOTING GUIDE

PROBLEM	POSSIBLE CAUSE	SOLUTION
NO RESPONSE WHEN THE POWER IS TURNED "ON".	POWER CORD UNPLUGGED.	PLUG POWER CORD FIRMLY INTO ELECTRICAL OUTLET IN WALL.
	DEFECTIVE POWER CORD.	CHECK ALL CONNECTIONS AND CONDITION OF ALL CORDS. DO NOT OPERATE WITH DAMAGED POWER CORD(S).
	TRIPPED CIRCUIT BREAKER.	RESET BREAKER FOR BUILDING.
	TRIPPED GROUND FAULT CIRCUIT INTERRUPTER.	RESET GFCI AT POWER SOURCE.
	THERMAL OVERLOAD ON THE MOTOR HAS TRIPPED.	TURN UNIT "OFF", WAIT 30 MINUTES AND RESTART UNIT.
CIRCUIT BREAKER FOR BUILDING "TRIPS".	OVERLOADED CIRCUIT.	REMOVE OTHER LOADS FROM CIRCUIT. RESET CIRCUIT BREAKER.
UNIT RUMBLES WHEN ATTEMPTING TO START.	LOW VOLTAGE OR LIMITED AMPERAGE IS SUPPLIED.	CHECK POWER SUPPLY. FOR MAXIMUM PERFORMANCE, THE UNIT REQUIRES A 120 VOLT 15 AMP CIRCUIT THAT IS LOAD FREE.
	EXTENSION CORD IS TOO LONG OR OF TOO HIGH A GAUGE.	EXTENSION CORD(S) SHOULD NOT EXCEED A TOTAL OF 50 FT IN LENGTH. USE GROUNDED 3-WIRE 12 GAUGE CORD(S).
	OTHER MACHINES OR LOADS ON SAME CORD OR CIRCUIT.	REMOVE OTHER LOADS FROM SAME CIRCUIT.
FILTER CHANGE INDICATOR "ON".	LOADED FILTERS.	CHANGE IN ACCORDANCE WITH OPERATING INSTRUCTIONS.
	EXCESSIVE RESTRICTIONS ON INTAKE.	REDUCE BENDS, LENGTH OF FLEX DUCT OR ELIMINATE RESTRICTIONS.
	CARBON FILTER HAS NOT BEEN REMOVED FROM POLYBAG.	REMOVE CARBON FILTER FROM POLYBAG.

Note: If unit does not start or malfunctions after carefully following the Troubleshooting Guide, call Abatement Technologies service department at 800-634-9091 (U.S.) or 905-871-4720 (Canada) for assistance.

COMPONENT REPLACEMENT AND CARE OF THE UNIT

Warning: To reduce the risk of fire, electrical shock or personal injury, always turn the unit "OFF" and disconnect power cord from supply receptacle before removing the control panel, replacing the HEPA filter and before cleaning or servicing the unit. The H2000LA is equipped with an automatic restart motor and blower assembly that will restart without warning after a temporary power interruption or recovery from a thermal overload (over-heating) condition. Keep clear of the motor and blower assembly at all times to reduce the risk of injury.

Occasionally a defective component will cause the unit to operate improperly or not at all. Any electrical component can fail. Refer to the Wiring Diagram and Wiring Schematic to diagnose the failure of any component. Diagnostics should only be performed by a technician qualified to service electrical equipment.

The unit should be cleaned with a damp cloth or a water-based cleaner/sanitizer. Do not use harsh chemicals, solvents or detergents to clean the unit.

Warning: Keep electrical components dry as their exposure to liquids poses a safety hazard and can damage components.

CERTIFICATION OF ROOM AIR FILTRATION UNITS

The Abatement Technologies room air filtration units have been tested by Intertek Testing Services (ITS) and are ETL and ETLIC (Canada) listed for electrical safety.

ITS is accredited by the U.S. Occupational Safety and Health Administration (OSHA) as a Nationally Recognized Testing Laboratory (NRTL).

LIMITED WARRANTY

Abatement Technologies, Inc (ATI) warrants that goods sold to the original user shall be free from defects in material and workmanship for a period of 1 year, except such as are commercially acceptable. This warranty does not include useful filter life. **ATI does not warrant that the goods sold are merchantable or fit for any particular purpose. ATI makes no warranties other than as stated in this paragraph. All other warranties, guaranties, or representations, express or implied, by operation of law or otherwise, are expressly disclaimed.** Goods found by ATI to be defective or not to conform to specification shall upon return be replaced or repaired by ATI without any additional charges, or, at ATI's option, ATI may refund the purchase price of such goods. ATI will pay return transportation charges on returned goods not exceeding the transportation charges applicable to shipment from original destination unless the returned goods are free from defect and conform to specifications. Returned goods which are found by ATI to be free from defect and to conform to specifications shall be held for Purchaser's shipping instructions, which instructions Purchaser shall furnish promptly upon request. **ATI's liability shall in no event extend beyond replacement, repair or refund of the purchase price and ATI shall not be liable under any circumstances for special, contingent or consequential damages, nor for loss, damages, or expenses directly or indirectly arising from the use of the goods, including without limitation, warehousing, labor, handling and service charges, die, equipment, or machine breakage, nor for costs, lost profits or loss of good will. The use of substitute, non-ATI parts and/or filters, in any ATI product, voids all warranties and performance claims. The remedies set forth herein are exclusive.**

For warranty information and assistance contact Abatement Technologies' Customer Service Department at 800-634-9091 (U.S.) or 905-871-4720 (Canada.)

Abatement Technologies' H2000LA high-efficiency air filtration units are originally equipped with true HEPA (High Efficiency Particulate Air) filters designed to maximize the performance of the equipment, and to meet the following industry standards:

Institute of Environment Sciences and Technology

IEST-RP-CC001.3 (Type A HEPA and ULPA Filters)

IEST-RP-CC021.1 (Testing HEPA and ULPA Filter Media)

Underwriters Laboratories

UL900, Class II (Flammability Specifications)

100% Efficiency Tested

Abatement Technologies HEPA filters are individually tested and certified to ensure that the completed filter provides an overall minimum efficiency of 99.97% when challenged by a thermally generated test aerosol, 0.3-microns in size, in accordance with IEST-RP-CC001.3.

Figure A: H2000LA Caster Assembly and Operation

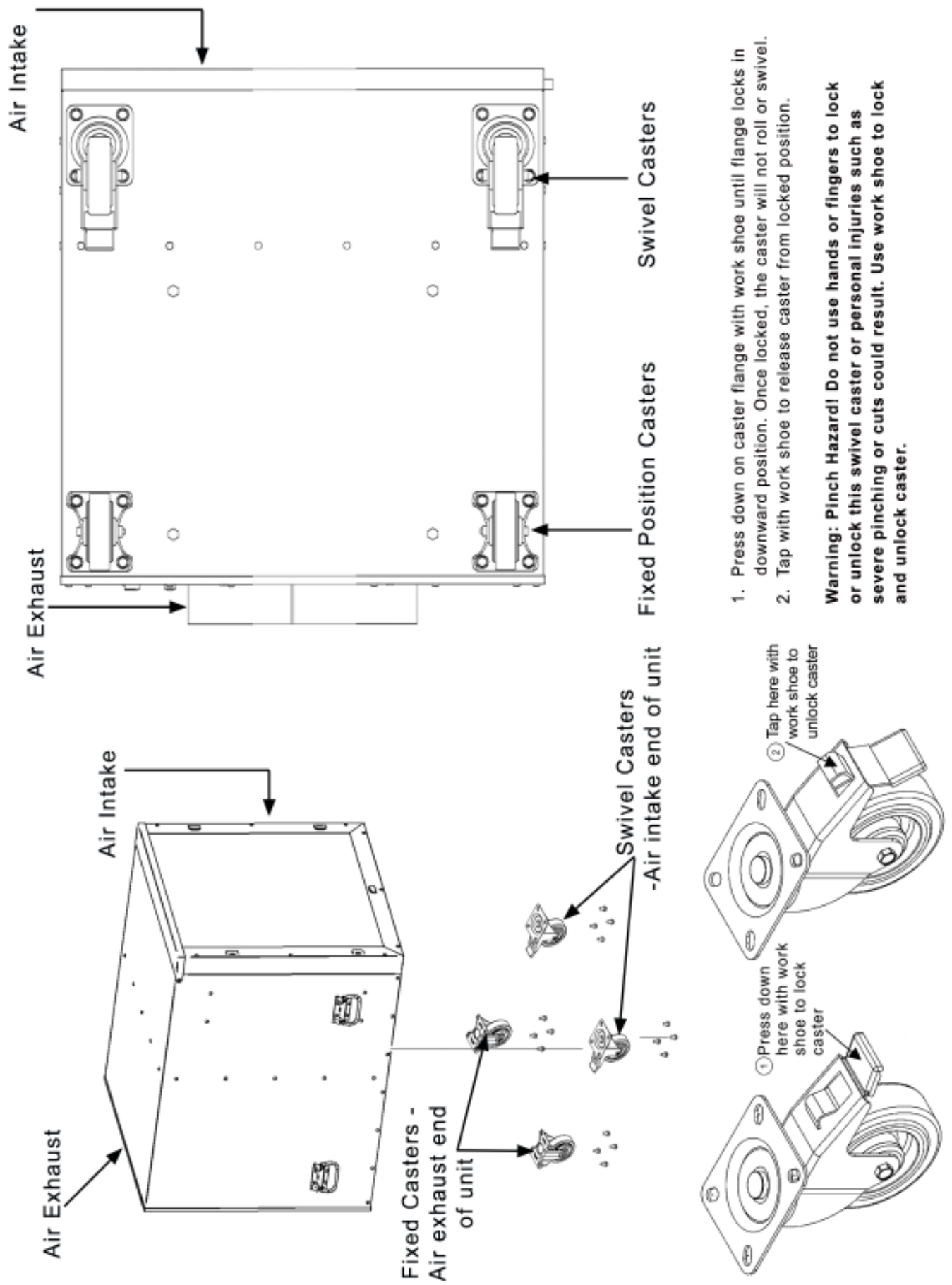

H2000LA Control Panel Wiring Diagram

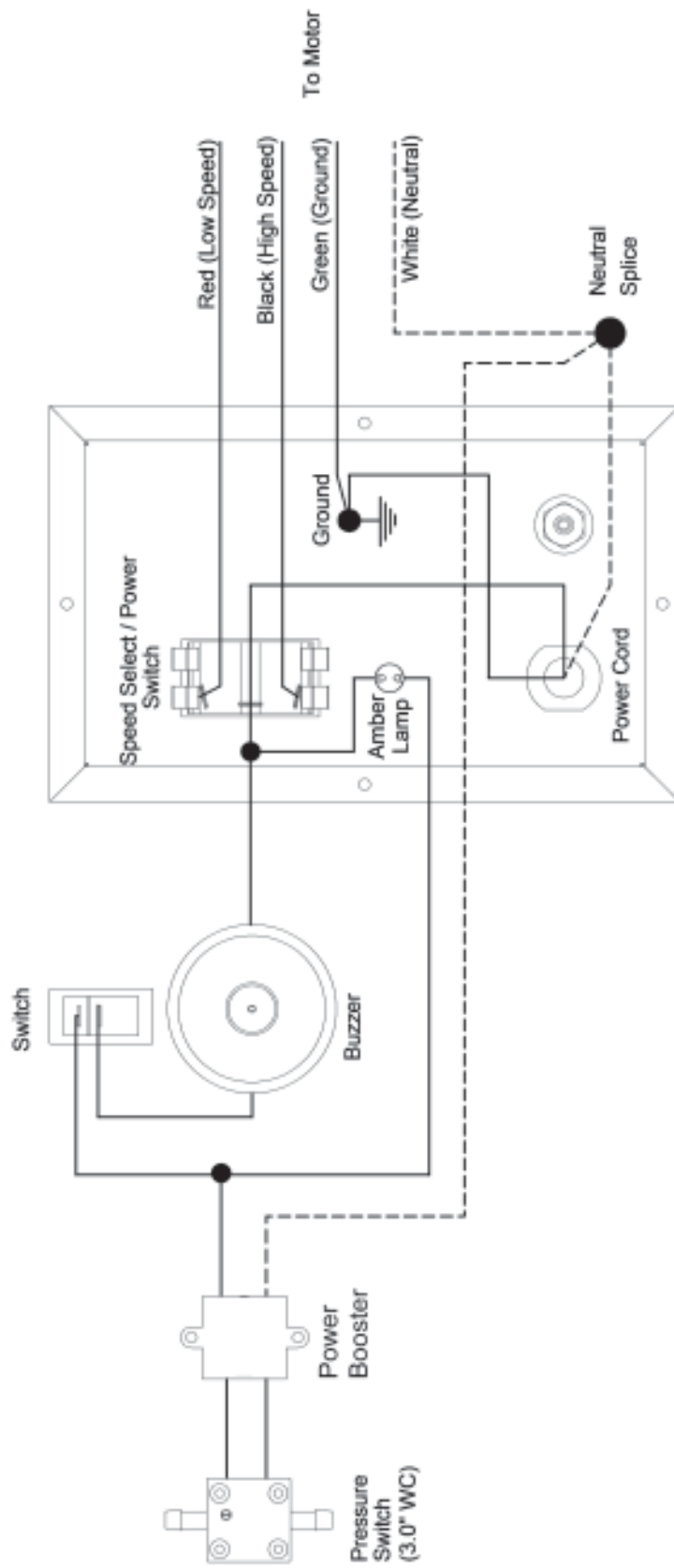

H2000LA Motor Wiring Diagram

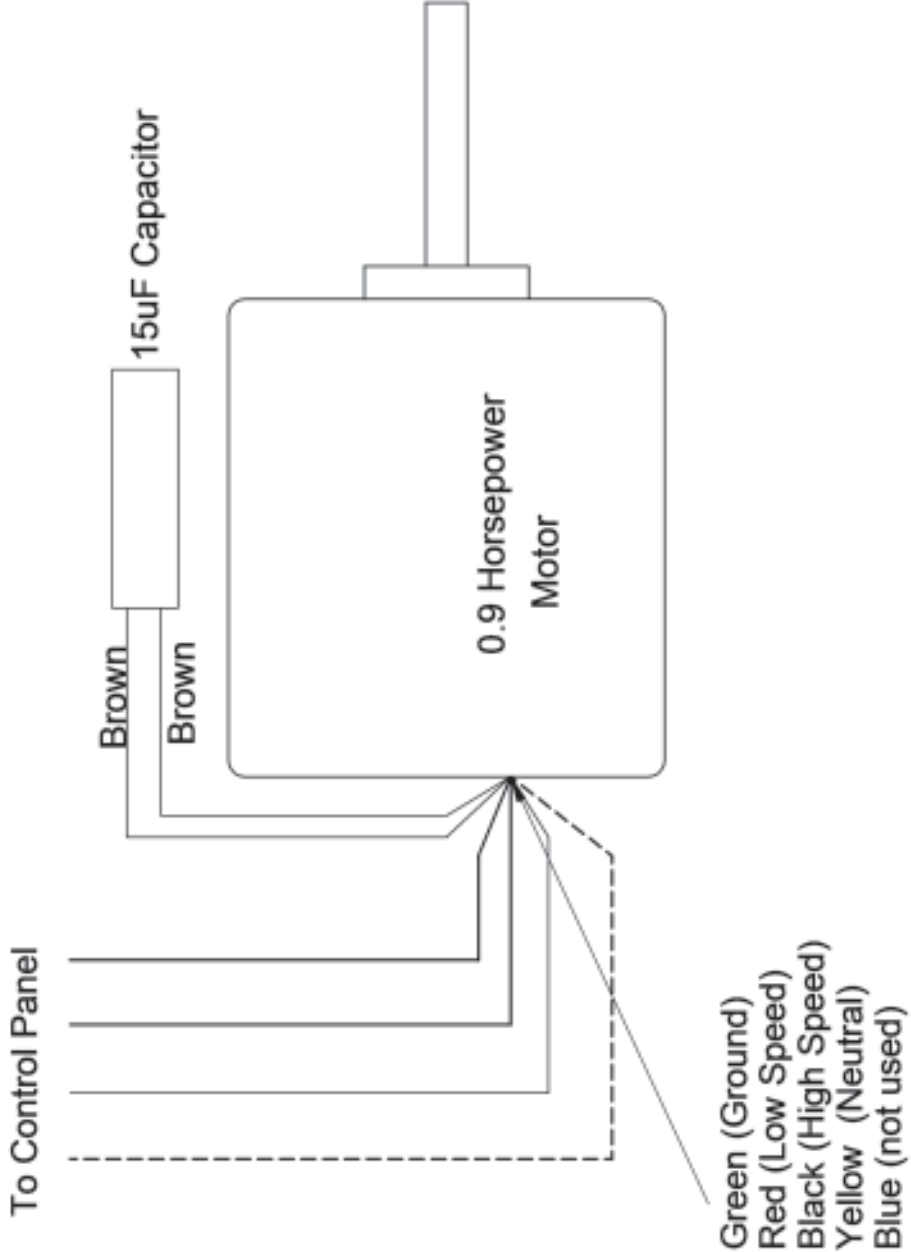

H2000LA Wiring Schematic

