



## MODELS: CAP600-UVP AND CAP600-UV INSTRUCTION MANUAL



**Abatement Technologies, Inc.**  
Georgia, USA  
800-634-9091

**Abatement Technologies, Ltd.**  
Ontario, Canada  
905-871-4720

# ABATEMENT TECHNOLOGIES CENTRAL AIR PURIFICATION SYSTEMS

## MODELS: CAP600-UVP AND CAP600-UV

### INSTRUCTION MANUAL

© Abatement Technologies 1998 All Rights Reserved. No reproduction of any portion of this work is permitted without the express written permission of Abatement Technologies, Inc.

#### **Note:**

- 1. Read and understand all operating instructions before installing and using the CAP600-UVP or CAP600-UV units.**
- 2. Save this instruction manual for future reference.**

This instruction manual provides important information on the installation and operation of the CAP600-UVP and CAP600-UV Central Air Purification Systems. These instructions must be carefully followed in order to install and operate the systems safely and correctly. If you have any questions regarding the installation, use or maintenance of the systems, call Abatement Technologies at 800-634-9091 (U.S.) or 905-871-4720 (Canada) for assistance.

#### **GENERAL INFORMATION**

The CAP600-UVP and CAP600-UV Central Air Purification Systems are designed to be used in conjunction with heating, ventilation and air conditioning (HVAC) systems that utilize ductwork to convey conditioned air to the various rooms throughout the home. The systems are installed in such a way that they filter a portion of the air being returned to the furnace/air conditioner for heating and cooling. Both systems utilize multiple stages of filtration including a High Efficiency Particulate Air (HEPA) filter that is certified to remove 99.97% of airborne particles 0.3 microns in size. The CAP600-UV includes an ultraviolet germicidal irradiation (UVGI) bulb. Ultraviolet germicidal irradiation breaks down bacteria, molds, and viruses. The CAP600-UVP includes a UVGI/Photolysis (UVGI/P) bulb. In addition to emitting UVGI, the bulb also creates a photolysis reaction, which is an oxidation process that neutralizes unpleasant odors and volatile organic compounds (VOC's).

The systems can be installed and set-up to operate continuously or when the furnace/air conditioner blower is operating. For maximum filtration, it is recommended that the units operate continuously so that air is filtered 24 hours a day.

**Note: To maximize UVGI and UVGI/P bulb life, the unit's power switch should be left in the "ON" position except when replacing the HEPA filter, bulb, or servicing the unit.**

#### **KEY COMPONENTS AND THEIR FUNCTION - Refer to Figures A and C.**

**Pre-filter Access Door** - downward opening door which provides access to and protects the primary and secondary filters.

**HEPA Filter Access Panel** - provides access to and protects the HEPA filter and the UVGI or UVGI/P bulb. Panel is secured to cabinet with sheet metal screws.

#### **Filters:**

**Primary** - removes coarse particulates (dust, dirt, etc.) from the air stream. Protects and extends the life of the secondary and HEPA filters.

**Secondary** - pleated filter which removes finer particulates. The particulate removal

capability also extends the life of the more expensive HEPA filter.

**Note: The Secondary filter is sealed in a poly bag in order to preserve the odor/vapor/gas adsorption capacity of the activated charcoal. Remove the filter from the poly bag before installing the CAP600-UVP or CAP600-UV.**

**HEPA** - has an efficiency rating of 99.97% in removing 0.3 micron size particles from the air stream.

**NOTE:** Before operating the unit, check to ensure that the HEPA filter hasn't loosened or shifted out of its proper position during transportation of the unit. Refer to the section of this manual entitled "Filter Change Procedure" for instructions on how to position and tighten the HEPA filter.

**Ultraviolet Germicidal Irradiation (UVGI) bulb** - assembly is installed inside the cylindrical HEPA filter frame of the CAP600-UV. The bulb irradiates prefiltered air before the air is pushed through the HEPA filter.

**UVGI/Photolysis (UVGI/P) bulb** - assembly is installed inside the HEPA filter frame of the CAP600-UVP. This bulb irradiates prefiltered air and also creates a photolysis reaction.

**Sight glass** - provides a means of checking the status of the UVGI or UVGI/P bulb. The sight glass is located adjacent to the Filter Change Indicator.

**Motorized impeller** - pulls air through the primary and secondary filters and pushes air through the HEPA filter.

**Power Switch** - rocker-arm style ON/OFF power switch which illuminates when it is in the "ON" position.

**Interlock Switch** - turns power to unit "OFF" if HEPA filter access panel is removed while unit is running. If a HEPA filter or bulb change is attempted without turning power to the CAP600-UVP or CAP600-UV "OFF", the interlock switch shuts the power "OFF" and prevents anyone from looking directly at UVGI rays that can cause temporary or permanent loss of vision and severe skin burns.

**Filter Change Indicator** - amber light which indicates excessive loading of the prefilters and that filter change procedures should be followed.

**Power cord** - number 18-3 AWG, 3 wire power cord with ground pin.

**Inlet and Outlet Collars** - provide a means of connecting the CAP600-UVP or CAP600-UV to the furnace return air plenum and cold air return with rigid or flexible duct.

## **ELECTRICAL REQUIREMENTS**

1. The CAP600-UVP and CAP600-UV require a minimum of 110 volts AC, 60 hz to operate properly; however, for maximum air flow performance, the units require 115 volts AC. Make certain that any extension cord(s) used do not reduce power to less than 110 volts. Use of a voltmeter to confirm adequate voltage is recommended. For maximum safety, the units should be connected to a 3 prong, properly grounded outlet equipped with a ground fault circuit interrupt device (GFCI). A GFCI will trip the circuit and stop the flow of electricity if any significant leakage of current is detected.
2. Power cords should never be exposed to water, heat, sharp or abrasive objects; in addition, they should never be kinked or crushed. Always replace damaged power cords immediately.

3. Extension cords used for the CAP600-UVP or CAP600-UV must be the number 18-3 AWG, 3 wire type. **NOTE: Use of larger numerical gauge (lower capacity wire) power cord(s) may result in damage to the UVGI and UVGI/P bulbs and ballast.** The cords must be in good condition, in continuous lengths (no splicing) and should not exceed a total of 25 feet in length. Use of too much cord can result in a voltage decrease and shorten the life of the UVGI and UVGI/P bulbs.

**Caution: To avoid damage to the unit's electrical system, do not connect or disconnect unit to power source unless the unit's power switch is in the "OFF" position.**

**Caution: To reduce risk of electrical shock do not expose the CAP600-UVP or CAP600-UV to water. Do not touch the electrical outlet or power cord(s) with wet hands or while standing on a wet surface.**

**Warning: Risk of electrical shock! Can cause injury or death. Always turn the CAP600- UVP or CAP600-UV "OFF" and disconnect it from the power source before replacing filters, bulb or servicing the unit.**

**Caution: To reduce risk of fire or electrical shock, do not use the CAP600-UVP or CAP600-UV unit with any solid state speed control device. Do not use in a cooking area.**

**CAUTION: For General Ventilating Use Only. Do not use to exhaust Hazardous Or Explosive Materials And Vapors.**

**Warning:** Any atmosphere that is combustible, flammable, explosive, oxygen deficient, and/or contains odors, vapors, gases or particulates that exceed permissible exposure levels should be evaluated by a certified industrial hygiene professional before being occupied. Such atmospheres may require the use of intrinsically safe equipment, specific engineering controls, and personal protective equipment in accordance with Occupational Safety and Health Administration (OSHA), Environmental Protection Agency (EPA), Canadian Standards Association (CSA), and other federal, state, provincial and local regulations.

**Warning:** This equipment is not classified as "intrinsically safe" and should not be used in the following potentially hazardous locations as defined by the Underwriters Laboratories: Class I Division I, Class I Division 2, Class 1 Zone 0, Class 1 Zone 1, Class 1 Zone 2, Class II Division 1, Class II Division 2, Class III Division 1, Class III Division 2. Refer to the UL web site: <http://www.ul.com/hazloc/define.htm>.

**LOCATION AND INSTALLATION OF UNIT - Refer to Figures B-1, B-2, and B-3**

**Note: The person installing the CAP600-UVP or CAP600-UV must be a licensed and trained HVAC technician**

**Note: The CAP600-UVP and CAP600-UV are designed for indoor use only.**

Since the units cannot remove existing dust and dirt from the air ducts, furnace blower and evaporator coil, these major HVAC components should be thoroughly cleaned using source-removal techniques before installation.

**Warning: Check to ensure that the CAP600-UVP and CAP600-UV are disconnected from electrical power source during installation process. Risk of electrical shock! Can cause serious injury or death. Always turn the electrical power switches and circuit breakers for the furnace/air conditioning unit(s) "OFF" before installing the CAP600-UVP or CAP600-UV.**

**Caution: When installing the CAP600-UVP or CAP600-UV always wear the proper personal protective equipment (particularly eye and hand protection) in accordance with federal, state, and employer regulations. Be extremely careful when handling sheet metal during installation because serious injury could result from coming in contact with sharp edges.**

The diagrams in Figures B-1, B-2 and B-3 are graphic displays which show how the CAP600-UVP or CAP600-UV connects to the heating/air conditioning system.

The following recommendations will facilitate installation and optimize the operating performance of the unit:

- ◆ Use the minimum length of ducting with the fewest possible number of turns or bends.
- ◆ Use 10" diameter round ducting. Rigid ducting is preferable to minimize turbulence and air losses; however, semi-rigid or flexible ducting is acceptable.
- ◆ Regardless of the type of ducting used, rigid "sweep" type, radiused connections should be used for all turns and bends.
- ◆ If flexible ducting is used, it must be as taut as possible to avoid "pancaking" or flattening.
- ◆ Seal all connections to prevent air leakage.

**Warning: Neither the CAP600-UVP nor the CAP600-UV should be installed in the line of sight of any inlet/outlet grilles or openings. The UVGI and UVGI/P bulbs produce intense ultraviolet light and heat. Direct contact with ultraviolet light and bulb can cause temporary or permanent loss of vision and severe skin burns. Never look at a UV lamp while it is illuminated. Never operate the CAP600-UVP or CAP600-UV before it is completely installed.**

1. Determine the location and position of the unit relative to the furnace/air conditioning unit.
2. The exhaust collar is packed inside the cabinet, underneath the secondary filter.
3. Determine which of the three exhaust outlet openings in the lower section of the cabinet will be used. **See Figure C.** Attach the exhaust collar to the cabinet with four sheet metal screws, making sure that the collar is facing outwards.
4. Attach the two solid cover plates to the other two exhaust outlet openings.

## **ELECTRICAL INSTALLATION**

There are four possible electrical installations for the CAP600-UVP or CAP600-UV as follows:

### **Installation Method #1- Continuous Operation**

- After connecting the CAP600-UVP or CAP600-UV to the heating/air conditioning system, plug the unit into a 115 VAC/15 AMP electrical outlet and turn the power switch to the "ON" position. The unit will run continuously unless the power switch is turned to the "OFF" position or there is an interruption in the power supply.

### **Installation Method #2 - Sail Switch Installation -Honeywell Model S688A or equivalent**

- After connecting the CAP600-UVP or CAP600-UV to the heating/air conditioning system, remove the HEPA filter access panel from the cabinet in order to make the appropriate wiring connections.
- Locate the red pigtail leads in the cabinet (see Figure D) and disconnect the marrette connector. Connect the 14/3 BX cable (which will run to the sail switch) through the 7/8" knockout located underneath the power cord. Connect the BX black wire to one red lead and the BX white wire to the other red lead. Connect the BX Ground wire to the motor channel in the CAP600-UVP or CAP600-UV.
- At the Sail Switch - BX black wire connects to the Common terminal. BX white wire connects to the Normally Open terminal. BX Ground wire connects to the switch metal enclosure.
- See the switch manufacturer's instructions to determine how to mount the switch in the cold air return duct and which springs to use. Also see Figure B-1.
- Reassemble the HEPA filter access panel to the unit.
- Plug the unit into a 115 VAC/15 AMP electrical outlet and turn the power switch to the "ON" position.

### **Installation Method #3 - Pressure Switch Installation - Columbus Electric Model RH3A or equivalent**

- After connecting the CAP600-UVP or CAP600-UV to the heating/air conditioning system, remove the HEPA filter access panel from the cabinet in order to make the appropriate wiring connections.
- Locate the red pigtail leads in the cabinet (see Figure D) and disconnect the marrette connector. Connect the 14/3 BX cable (which will run to the pressure switch) through the 7/8" knockout located underneath the power cord. Connect the BX black wire to one red lead and the BX white wire to the other red lead. Connect the BX Ground wire to the motor channel in the CAP600-UVP or CAP600-UV.

- At the Pressure Switch - BX black wire connects to the Common terminal. BX white wire connects to the Normally Open terminal. BX Ground wire connects to the switch metal enclosure.
- See the switch manufacturer's instructions to determine how to mount the switch in the supply air duct. Also see Figure B-2.
- Reassemble the HEPA filter access panel to the unit.
- Plug the unit into a 115 VAC/15 AMP electrical outlet and turn the power switch to the "ON" position.

#### **Installation Method #4 - Air Flow Switch Installation - Dwyer Model 530 or equivalent**

- After connecting the CAP600-UVP or CAP600-UV to the heating/air conditioning system, remove the HEPA filter access panel from the cabinet in order to make the appropriate wiring connections.
- Locate the red pigtail leads in the cabinet (see Figure D) and disconnect the marrette connector. Connect the 14/3 BX cable (which will run to the air flow switch) through the 7/8" knockout located underneath the power cord. Connect the BX black wire to one red lead and the BX white wire to the other red lead. Connect the BX Ground wire to the motor channel in the CAP600-UVP or CAP600-UV.
- At the Air Flow Switch - BX black wire connects to the Common terminal. BX white wire connects to the Normally Open terminal. BX Ground wire connects to the switch metal enclosure.
- See the switch manufacturer's instructions to determine how to mount the switch in the air duct. Also see Figure B-3.
- Reassemble the HEPA filter access panel to the unit.
- Plug the unit into a 115 VAC/15 AMP electrical outlet and turn the power switch to the "ON" position.

#### **UVGI, UVGI/PHOTOLYSIS BULBS**

The UVGI and UVGI/P bulbs each have a rated service life of approximately 1 year, provided they are **not**: (a) dropped or otherwise damaged, and (b) turned "ON" and "OFF" more than once every 8 hours. As stated in the GENERAL INFORMATION section of this instruction manual, "To maximize UVGI and UVGI/P is bulb life, the unit's power switch should be left in the "ON" position except when replacing the HEPA filter, bulb or servicing the unit." If the CAP600-UVP and CAP600-UV are used in the recommended manner, bulb life will closely approximate 1 year.

Periodically, check the status of the bulb by looking through the sight glass in the CAP600-UVP or CAP600-UV. If no glow is visible, the bulb or ballast has burned out.

**Note: Bulb should be replaced once each year.**

## **FILTERS**

The CAP600-UVP and CAP600-UV have 3 stages of filtration:

Stage 1: 1" thick particulate (dust, dirt, etc.) primary filter (Part #F621).

Stage 2: 2" thick charcoal impregnated gas/odor/particulate secondary filter (Part #VL602).

Stage 4: 99.97% efficient High Efficiency Particulate Air (HEPA) filter (Part #H610C-99).

**NOTE: The CAP600-UVP or CAP600-UV and the furnace or air conditioning system must be operating in order to check filter loading. Do not operate the CAP600-UVP or CAP600-UV unless the primary, secondary and HEPA filters are installed and the filter access door and panel are closed.**

### **When Filter Replacement Is Required**

Check the status of the amber filter change indicator light monthly or more frequently. If this light turns "ON", one or more of the prefilters need replacement in order to maintain the peak operating performance of the unit. The time interval between filter changes is determined by the size and concentration of airborne contaminants, temperature and humidity conditions, and duration of use. Due to the design of the CAP600-UVP and CAP600-UV, the filter change indicator system does not measure pressure drop across the HEPA filter. The HEPA filter should be changed approximately every 2 years.

**Caution: Abatement Technologies Central Air Purification units are designed to meet or exceed standards for high efficiency air filtration equipment. Use only Abatement Technologies parts, including replacement filters. The filters are not reusable; therefore, do not attempt to clean and reuse them. Use of non-Abatement Technologies parts and filters voids the product warranty and all performance claims.**

### **FILTER AND BULB CHANGE PROCEDURE - Refer to Figures A and C.**

**Warning: Always turn the CAP600-UVP or CAP600-UV and furnace/air conditioning system "OFF" before replacing the HEPA filter, bulb or servicing the unit. The UVGI and UVGI/P bulbs produce intense ultraviolet light and heat. Direct contact with ultraviolet light and bulb can cause temporary or permanent loss of vision and severe skin burns. Never look at a UV lamp while it is illuminated.**

#### **To Change The Primary Filter:**

1. Pull up on the door latch and open the Prefilter Access door.
2. Remove the primary filter (top filter) and replace it with a new one (Part #F621).
3. Close the door and lock it in this position by pushing down on the latch. Make sure the door is completely closed before closing latch.
4. Operate the unit and if the filter change indicator remains "ON" after changing the primary filter, the secondary filter should be replaced.

#### **To Change The Secondary Filter:**

1. Open the Prefilter Access door.
2. Remove the secondary filter (second stage filter) and replace it with a new one (Part #VL602).
3. Close the door and lock it in position.

#### **To Change The HEPA Filter and UVGI or UVGI/P Bulb: Refer to Figures A and C**

**Warning: Both the UVGI and UVGI/P bulbs get extremely hot during operation. Unit must be turned "OFF" for at least 15 minutes before replacing or cleaning bulb. Touching the bulb immediately after turning unit "OFF" will result in severe skin burns.**

**Caution: Always turn the CAP600-UVP or CAP600-UV unit and furnace/air conditioning system "OFF" before replacing the HEPA filter and/or bulb. Place a piece of tape over the ON/OFF switches to ensure that they remain in the "OFF" position while replacing the HEPA filter and/or bulb.**

1. Turn the CAP600-UVP or CAP600-UV and the furnace/air conditioning system "OFF" and remove the HEPA filter access panel.
2. Disconnect the bulb from the ballast assembly (which is mounted on a shelf just above the HEPA filter) by unplugging the female connector from the 4 pin end (top) of the bulb.
3. Using a 1/2" wrench, loosen the 2 HEPA filter retaining bolts by turning them in a counterclockwise direction and gently slide the HEPA filter out of the cabinet.
4. The bulb is mounted inside the HEPA filter as follows:
  - a) the top section is secured in place by a metal retaining bracket which fits snugly inside the top section of the metal HEPA filter frame.
  - b) the bottom of the bulb fits snugly inside a metal retaining clip which is attached to the base plate of the HEPA filter.
5. To change the HEPA filter:
  - a) grasp the ceramic section at top of bulb (4 pin end of bulb) and remove bulb from inside of HEPA filter. **Do not touch the glass section of the bulb with bare hands because skin oils will reduce the effectiveness of the bulb.**
  - b) pull up on the metal retaining bracket until it dislodges from the HEPA filter frame.
  - c) replace the HEPA filter (part # H610C-99).
  - d) position metal retaining bracket over top section of new HEPA filter frame and push down on the bracket until it snaps into place against frame.
  - e) insert bottom of bulb into the retaining clip at base of HEPA filter.
  - f) snap the ceramic section at top of bulb (4 pin end) into the spring clip of the metal retaining bracket attached to HEPA filter.
  - g) place the new HEPA filter (which now contains the bulb and bracket assemblies) on the edge of the ^ - shaped HEPA filter support bracket which is mounted inside the cabinet.
  - h) plug the 4 pin end of the bulb into the female connector (from ballast).
  - i) push the HEPA filter and its ^ -shaped support bracket back into cabinet.
  - j) tighten the filter retaining bolts and reattach HEPA filter access panel.
  - k) turn the CAP600-UVP or CAP600-UV and furnace/air conditioning system back "ON".
6. To change the UVGI or UVGI/P bulb:
  - a) repeat step 5 a) above.
  - b) replace the UVGI or UVGI/P bulb.
  - c) repeat steps 5 e), f), h), i), j), k).

## CAP600-UVP and CAP600-UV SPECIFICATIONS

FEATURE	CAP600-UVP, CAP600-UV
Net weight with filters:	55 lbs.
Shipping weight:	63 lbs.
Dimensions: Width x Depth x Height	16 3/4" x 16 5/8" x 29"
Electrical power rating:	115 volts, 60 hz.
Motorized impeller:	600 cfm @ 0 inches of water column (WC) static pressure, 125 watts, thermal overload protection with automatic reset, 60 hz, single phase.
Airflow:	575 - 675 cfm when operated in conjunction with HVAC motor/blower.
Cabinet material:	22 gauge powder coated steel
Cabinet seams:	riveted construction
Noise level:	63 dBA
Power switch/indicator:	rocker-arm style power ON/OFF switch which illuminates when it is in the "ON" position
Filter change indicator:	amber light
Power cord:	6 ft. long with 3 prong plug
Primary filter:	1" thick, coarse particulate filter. Conforms to UL900 Class II requirements for flammability.
Secondary filter:	2" thick, charcoal impregnated odor/vapor/gas/particulate filter. Conforms to UL900 Class II requirements for flammability.
HEPA filter:	High Efficiency Particulate Air filter which is 99.97% efficient against 0.3 micron size particles. Conforms to UL900 Class II requirements for flammability.
Accessories included with unit:	Exhaust collar and two solid cover plates.
Bulb type:	CAP600-UVP - ultraviolet germicidal irradiation/Photolysis bulb. CAP600-UV - UVGI only
Interlock switch	Turns power to unit "OFF" if HEPA filter access panel is removed while unit is running.

Note: Specifications subject to change without notice.

## TROUBLESHOOTING GUIDE

PROBLEM	POSSIBLE CAUSE	SOLUTION
Unit won't start when power switch is turned "ON".	Power cord.  Tripped circuit breaker.  Tripped GFCI.  Thermal overload on motorized impeller has tripped.	Check all connections and condition of cord. <b>DO NOT OPERATE UNIT WITH DAMAGED POWER OR EXTENSION CORD(S).</b>  Reset building breaker.  Reset GFCI at power source.  Turn unit "OFF", wait 20-30 minutes and restart.
Unit won't start when furnace blower turns "ON".	Duct mounted switch.	Check all wiring and connections between duct mounted switch and unit.  Replace duct mounted switch.
Amber filter change indicator is "ON".  Bulb doesn't glow.	Secondary filter has not been removed from poly bag.  Loaded prefilters.  Electrical connection.  Burned out bulb.  Burned out ballast or interlock switch.	Remove filter from poly bag.  Refer to <b>FILTER AND BULB CHANGE PROCEDURE</b> section of the instruction manual.  Check connection between bulb and ballast.  Refer to the section entitled <b>To Change the HEPA Filter and UVGI or UVGI/P Bulb.</b>  Call Abatement Technologies Technical Support Department for assistance.

**Note:** If the unit does not start or malfunctions after carefully follow the Troubleshooting Guide, call Abatement Technologies service department at 800-634-9091 (U.S.) or 905-871-4720 (Canada) for assistance.

### COMPONENT REPLACEMENT

**Caution:** Always turn the CAP600-UVP or CAP600-UV "OFF" and disconnect it from the power source before servicing the unit. Unit is equipped with automatic restart motorized impeller and may restart without warning. Keep clear of motorized impeller at all times.

Occasionally a defective component will cause the unit to operate improperly or not at all. Any electrical component can fail. Refer to Figure E Wiring Diagram and Figure F Wiring Schematic to diagnose the failure of any component. Diagnostics and servicing should only be performed by a qualified technician.

**Warning:** Use only Abatement Technologies prefilters, HEPA filters, and replacement parts. Substitute filters and parts void the warranty, jeopardize worker and environmental safety, and adversely affect engineered performance levels.

## CARE OF THE UNIT

**Warning: Both the UVGI and UVGI/P bulbs get extremely hot during operation. Unit must be turned "OFF" for at least 15 minutes before replacing or cleaning bulb. Touching the bulb immediately after turning unit "OFF" will result in severe skin burns.**

The cabinet for the CAP600-UVP and CAP600-UV is powder-coated and should be cleaned with a damp cloth or a water-based cleaner/sanitizer. Do not use harsh chemicals, solvents or detergents to clean the powder-coated surface.

Inspect the UVGI or UVGI/P bulb every 6 months. If the bulb is soiled, clean the glass with a cotton ball and alcohol.

Keep all of the unit's electrical components dry as their exposure to liquids poses a safety hazard and can damage components.

## CERTIFICATION OF UNIT

The CAP600-UVP and CAP600-UV Central Air Purification units have been tested by Intertek Testing Services (ITS) and are all ETL listed.

ITS is accredited by the U.S. Occupational Safety and Health Administration (OSHA) as a Nationally Recognized Testing Laboratory (NRTL).

## Limited Warranty

Abatement Technologies, Inc (ATI) warrants that goods sold to the original user shall be free from defects in material and workmanship for a period of 2 years, except such as are commercially acceptable. The warranty on the lamps is 1 year from the date of purchase. This warranty does not include useful filter life. **ATI does not warrant that the goods sold are merchantable or fit for any particular purpose. ATI makes no warranties other than as stated in this paragraph. All other warranties, guaranties, or representations, express or implied, by operation of law or otherwise, are expressly disclaimed.** Goods found by ATI to be defective or not to conform to specification shall upon return be replaced or repaired by ATI without any additional charges, or, at ATI's option, ATI may refund the purchase price of such goods. ATI will pay return transportation charges on returned goods not exceeding the transportation charges applicable to shipment from original destination unless the returned goods are free from defect and conform to specifications. Returned goods which are found by ATI to be free from defect and to conform to specifications shall be held for Purchaser's shipping instructions, which instructions Purchaser shall furnish promptly upon request. **ATI's liability shall in no event extend beyond replacement, repair or refund of the purchase price and ATI shall not be liable under any circumstances for special, contingent or consequential damages, nor for loss, damages, or expenses directly or indirectly arising from the use of the goods, including without limitation, warehousing, labor, handling and service charges, die, equipment, or machine breakage, nor for costs, lost profits or loss of good will. The use of substitute, non-ATI parts and/or filters, in any ATI prod-**

**uct, voids all warranties and performance claims. The remedies set forth herein are exclusive.**

For warranty information and assistance contact Abatement Technologies' Customer Service Department at 800-634-9091 (U.S.) or 905-871-4720 (Canada.)

Abatement Technologies' HEPA-AIRE® and HEPA-CARE® high-efficiency air filtration units are originally equipped with true HEPA (High Efficiency Particulate Air) filters designed to maximize the performance of the equipment, and to meet the following industry standards:

**Institute of Environment Sciences and Technology**

IEST-RP-CC001.3 (Type A HEPA and ULPA Filters)

IEST-RP-CC021.1 (Testing HEPA and ULPA Filter Media)

**Underwriters Laboratories**

UL900, Class II (Flammability Specifications)

**100% Efficiency Tested**

Abatement Technologies HEPA filters are individually tested and certified to ensure that the completed filter provides an overall minimum efficiency of 99.97% when challenged by a thermally generated test aerosol 0.3-microns in size, in accordance with IEST-RP-CC001.3.

**Caution: Do Not Substitute**

Use only Abatement Technologies filters in this product. Substitution of other filters may reduce the unit's filtration efficiency, airflow and filter life, and voids all related performance claims and product warranties.

FIGURE A: CAP600-UVP & CAP600-UV FILTER REPLACEMENT

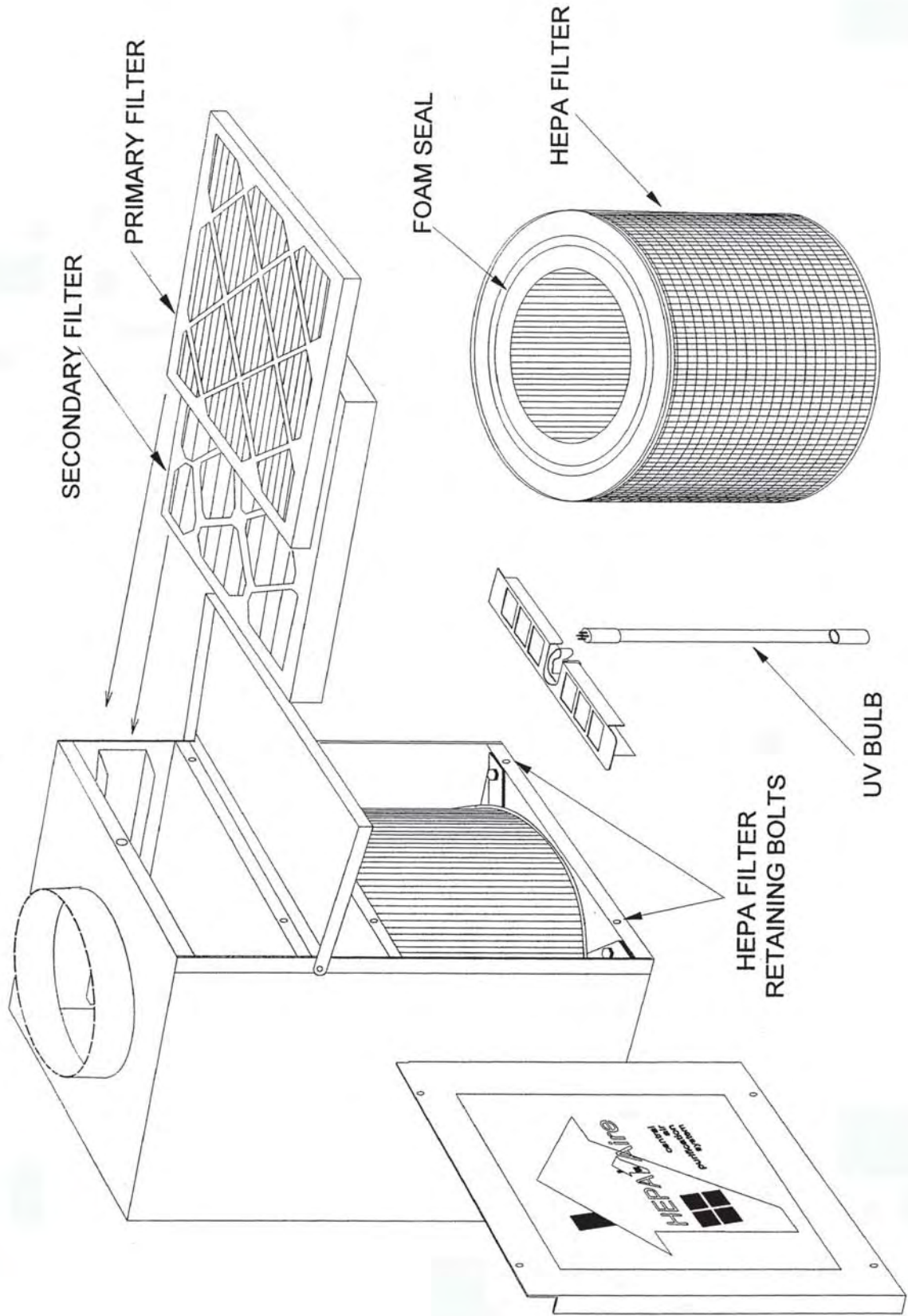

FIGURE B-1: CAP600-UVP & CAP600-UV INSTALLATION WITH SAIL SWITCH

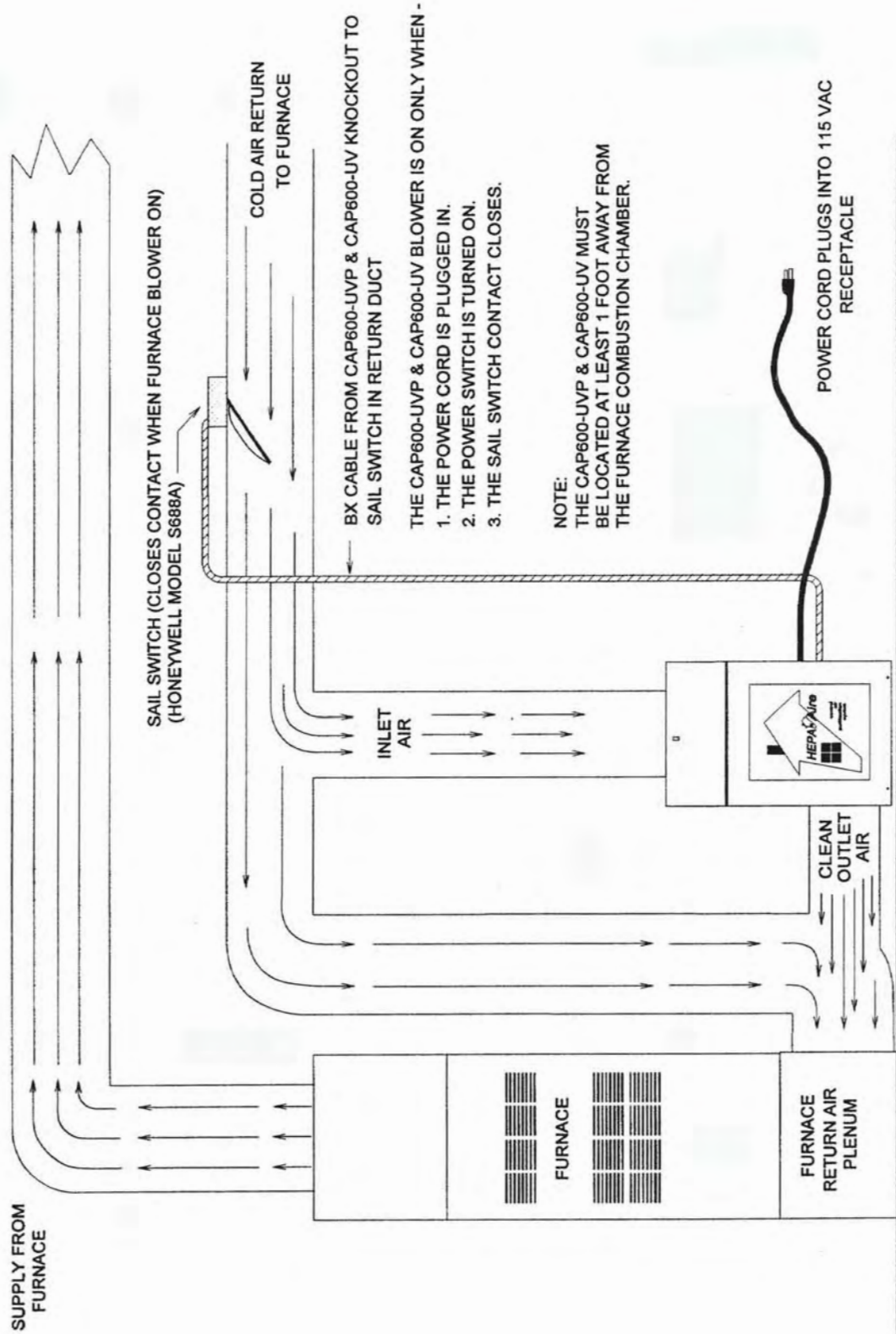

FIGURE B-2: CAP600-UVP & CAP600-UV INSTALLATION WITH PRESSURE SWITCH

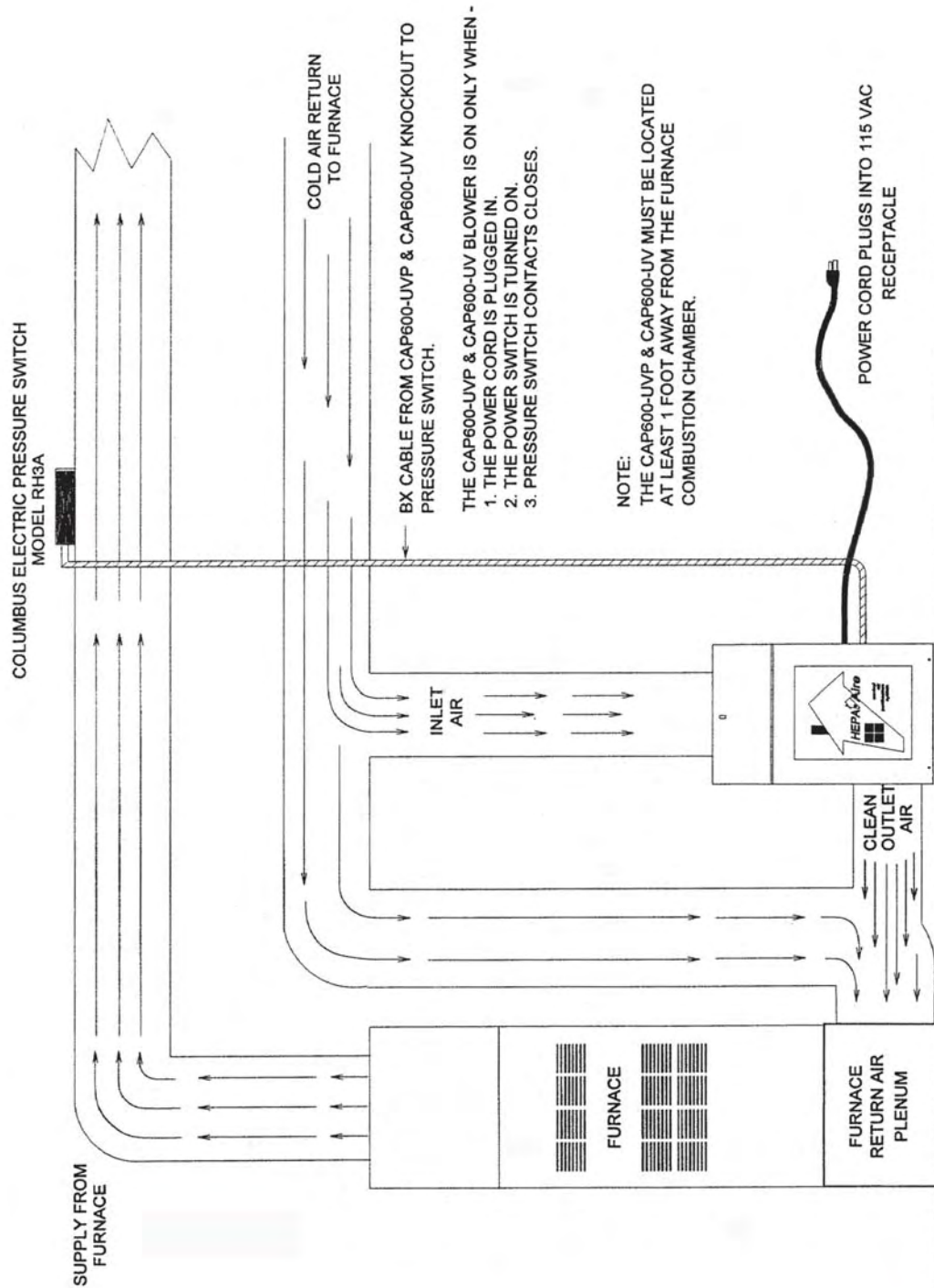

FIGURE B-3: CAP600-UVP & CAP600-UV INSTALLATION WITH AIR FLOW SWITCH

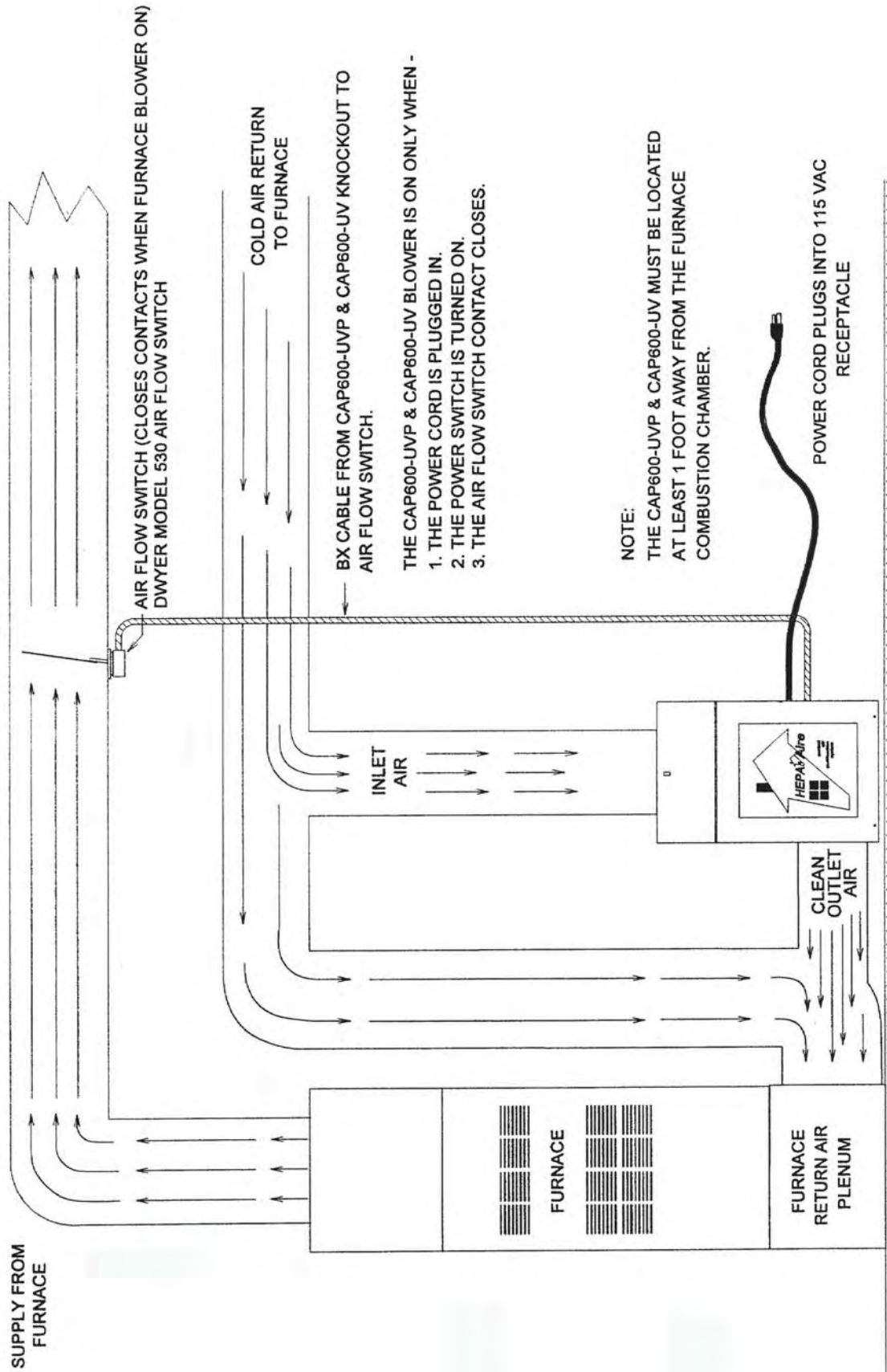

FIGURE C: CAP600-UVP & CAP600-UV

INSTALLATION OF EXHAUST COLLAR

1. THE EXHAUST COLLAR IS PACKED INSIDE THE CAP600-UVP & CAP600-UV CABINET, UNDERNEATH THE SECONDARY FILTER.
2. SELECT WHICH EXHAUST OPENING WILL BEST SUIT THE INSTALLATION. SEAL THE OTHER TWO OPENINGS WITH COVER PLATES. USE FOUR SCREWS TO INSTALL EACH PLATE.
3. USE THE FOUR SCREWS TO INSTALL THE EXHAUST COLLAR MAKING SURE THE COLLAR FACES THE OUTSIDE OF THE CAP600-UVP & CAP600-UV CABINET.

OPERATION OF DOOR LATCH

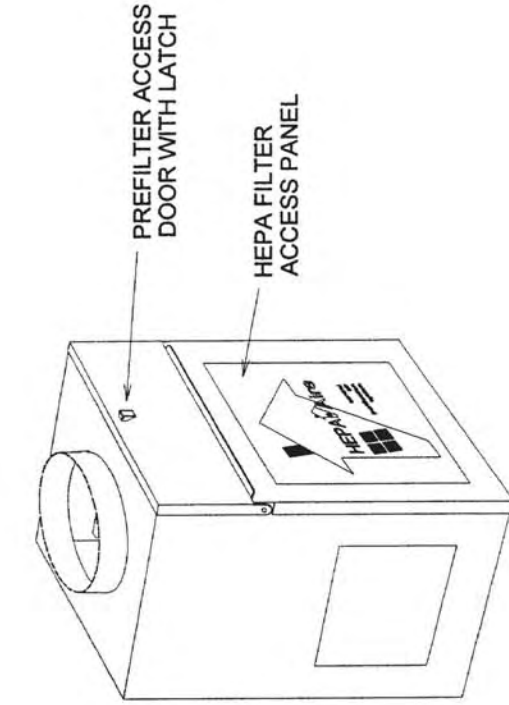
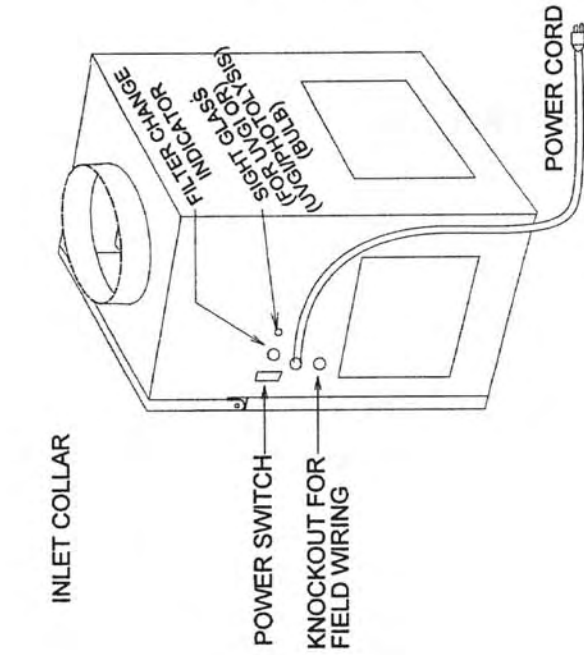
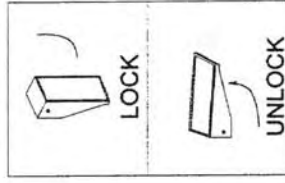

FIGURE D: Referenced on pages 4 and 5 in Manual

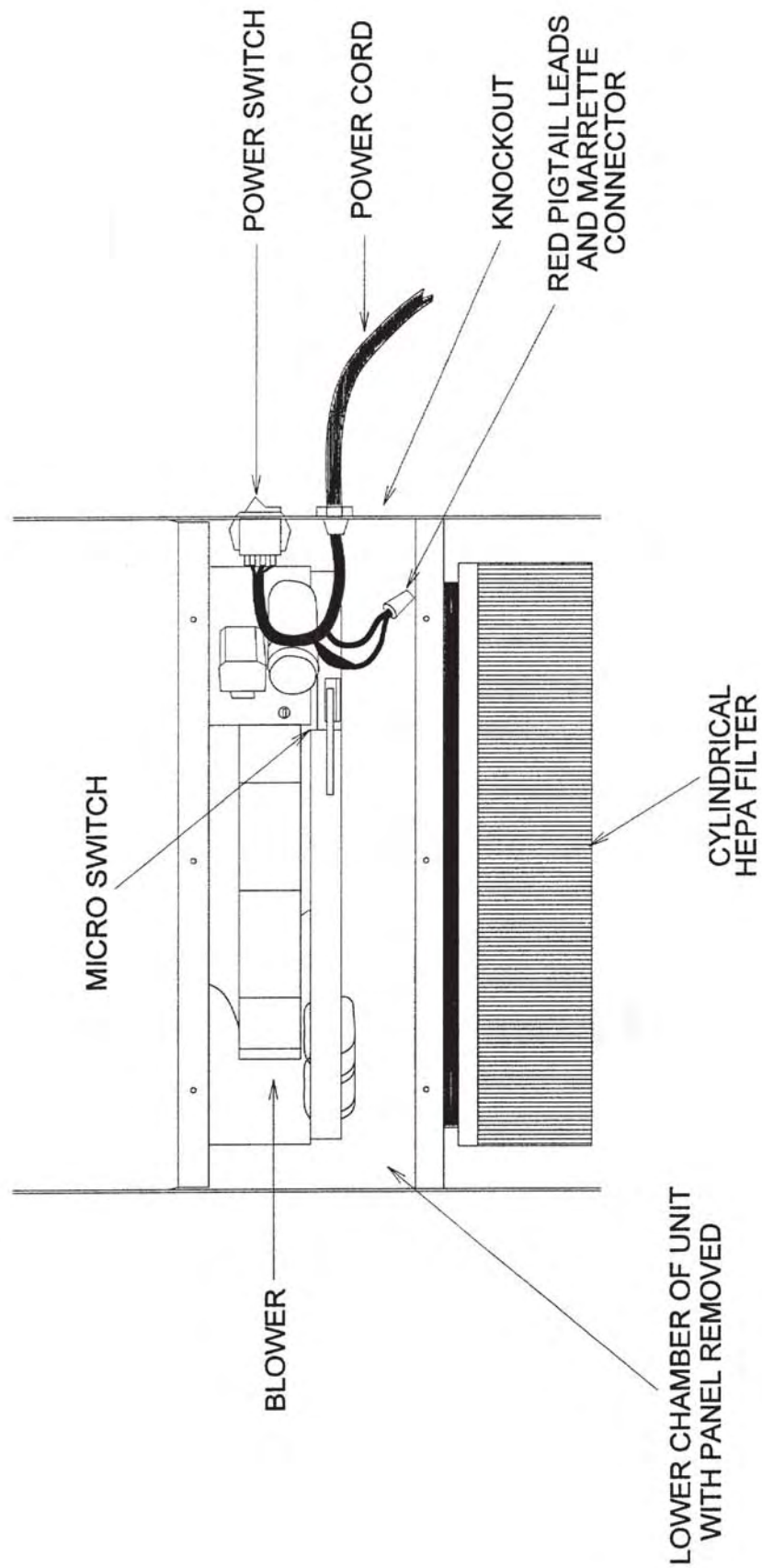
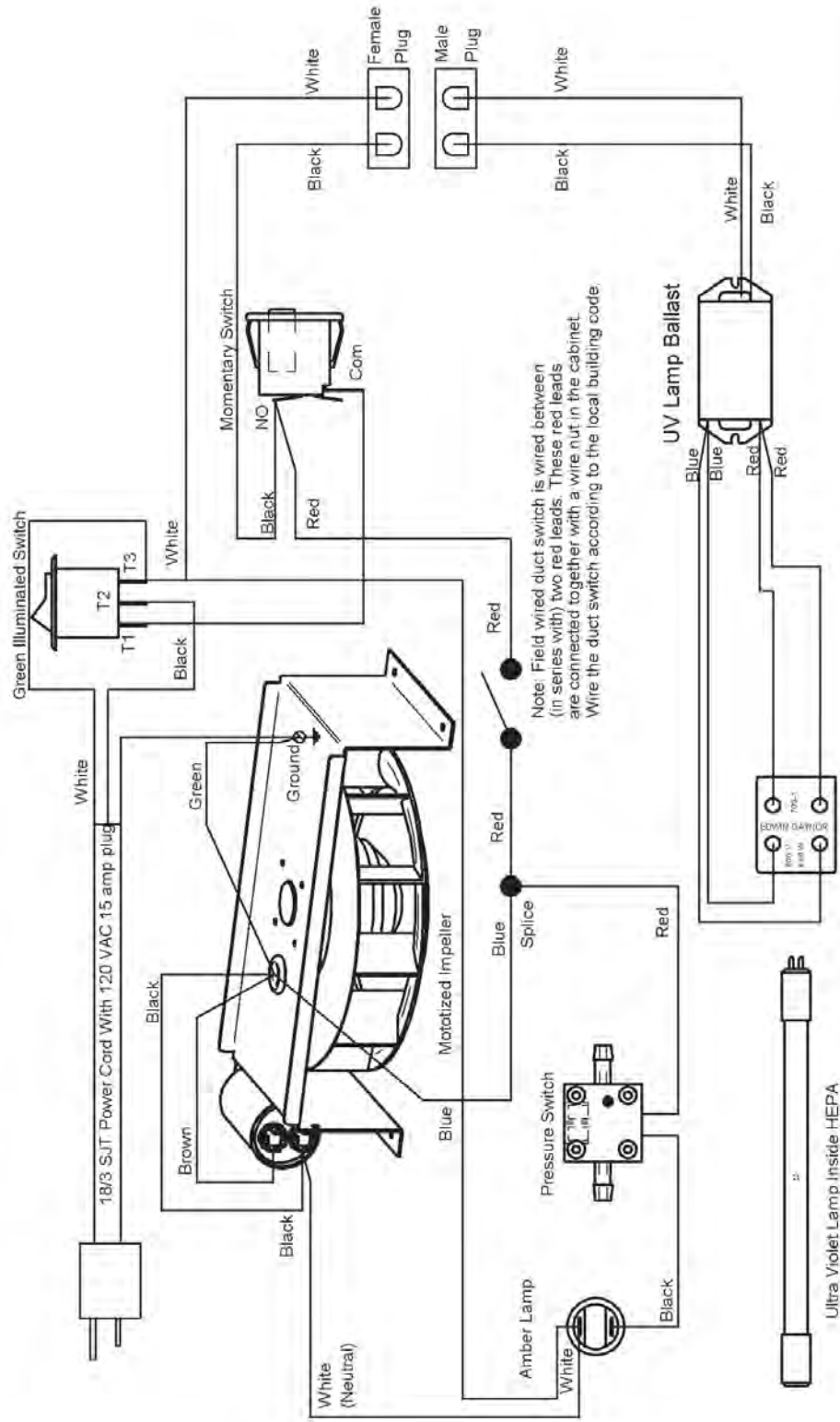

FIGURE E: CAP600-UVP & CAP600-UV WIRING DIAGRAM



TITLE: CAP600UV & CAP600UVP Wiring Diagram

Material:	SIZE: A-WIDE	DWG NO.:	REV#:
DRAWN: Dan	NAME: Dan	DATE: 02/01/05	DESC: SCALE:
WEIGHT:			SHEET 2 OF 1

FIGURE F: CAP600-UVP & CAP600-UV WIRING SCHEMATIC

